

G Series Console

Geothermal/Water Source Heat Pump

- R-410A Refrigerant
- 0.75-1.5 Tons Single Speed

Design Features

Factory Options

Accessories

Dimensional Data

Physical Data

Performance Data

Engineering Guide Specifications



Table of Contents

Model Nomenclature	4
AHRI Data	5-6
The Console	7-8
Inside the Console	8
Controls	9-15
Application Notes	16-18
Water Quality	18
Installation Notes	19
Selection Example	20-21
Dimensional Data	22-28
Physical Data	29
Electrical Data	29
Auxiliary Heat Ratings	29
Blower Performance Data	30
Pressure Drop	30
Correction Factor Tables	30
Reference Calculations	31
Legend and Notes	31
Operating Limits	31
Performance Data	32-35
Wiring Schematics	36-40
Engineering Guide Specifications	41-42

Model Nomenclature

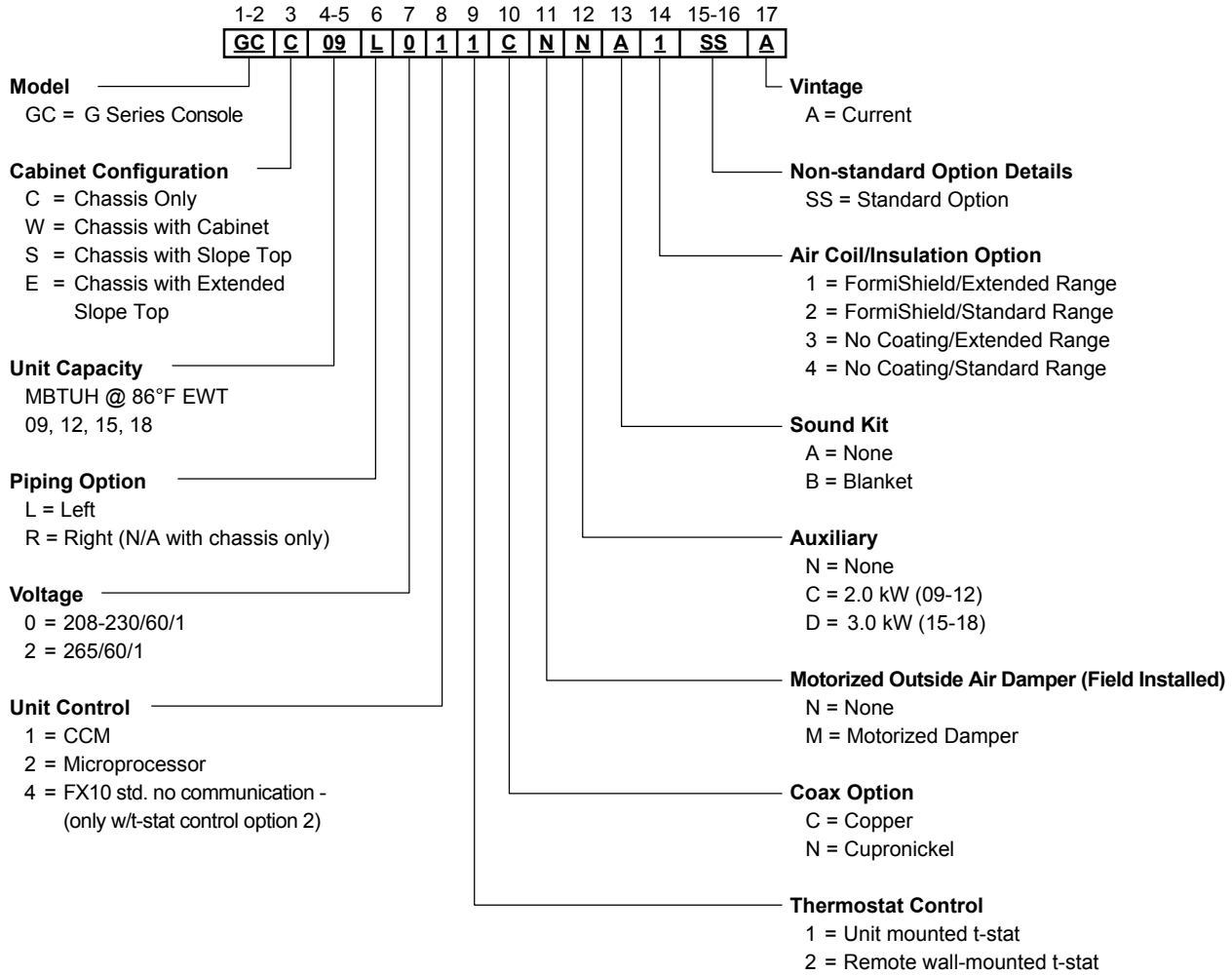

All G Series product is Safety listed under UL1995 thru ETL and performance listed with AHRI in accordance with standard 13256-1.

AHRI Data

PSC Motors

AHRI/ASHRAE/ISO 13256-1

English (IP) Units

Model	Flow Rate		Water Loop Heat Pump				Ground Water Heat Pump				Ground Loop Heat Pump			
			Cooling EWT 86°F		Heating EWT 68°F		Cooling EWT 59°F		Heating EWT 50°F		Cooling EWT 77°F		Heating EWT 32°F	
	gpm	cfm	Capacity Btuh	EER Btuh/W	Capacity Btuh	COP	Capacity Btuh	EER Btuh/W	Capacity Btuh	COP	Capacity Btuh	EER Btuh/W	Capacity Btuh	COP
09	2.5	300	8,500	13.4	10,500	4.4	10,200	22.5	8,700	3.8	9,000	16.0	6,700	3.1
12	3.5	350	10,500	12.3	14,400	4.3	12,400	19.5	11,800	3.7	11,000	14.2	9,500	3.5
15	4.5	450	13,500	13.6	17,000	4.9	16,200	22.0	14,000	4.1	14,200	15.9	10,500	3.4
18	5.5	500	16,200	12.5	21,000	4.4	19,000	19.6	17,000	3.7	16,600	15.1	13,300	3.1

Cooling capacities based upon 80.6°F DB, 66.2°F WB entering air temperature

Heating capacities based upon 68°F DB, 59°F WB entering air temperature

All ratings based upon operation at the lower voltage of dual voltage rated models.

12/14/09

Energy Star Compliance Table

Model	Tier 1		Tier 2	
	Ground Water	Ground Loop	Ground Water	Ground Loop
09	Yes	No	Yes	No
12	Yes	Yes	No	No
15	Yes	Yes	Yes	No
18	Yes	Yes	No	No

12/17/10

Energy Star Rating Criteria

In order for water-source heat pumps to be Energy Star rated they must meet or exceed the minimum efficiency requirements listed below. Please note there are 3 Tier levels that dictate minimum efficiency for water-to-air heat pumps. Only one tier level is active at a given moment.

Tier 1: 12/1/2009 – 12/31/2010

	EER	COP
Closed loop water-to-air	14.1	3.3
Open loop water-to-air	16.2	3.6
Closed loop water-to-water	15.1	3.0
Open loop water-to-water	19.1	3.4

Tier 2: 1/1/2011 – 12/31/2011

	EER	COP
Closed loop water-to-air	16.1	3.5
Open loop water-to-air	18.2	3.8
Closed loop water-to-water	15.1	3.0
Open loop water-to-water	19.1	3.4

Tier 3: 1/1/2012 – No Effective End Date Published

	EER	COP
Closed loop water-to-air	17.1	3.6
Open loop water-to-air	21.1	4.1
Closed loop water-to-water	16.1	3.1
Open loop water-to-water	20.1	3.5

AHRI Data cont.

The performance standard AHRI/ASHRAE/ISO 13256-1 became effective January 1, 2000 and replaces ARI Standards 320, 325, and 330. This new standard has three major categories: Water Loop (comparable to ARI 320), Ground Water (ARI 325), and Ground Loop (ARI 330). Although these standards are similar there are some differences:

Unit of Measure: The Cooling COP

The cooling efficiency is measured in EER (US version measured in Btuh per Watt. The Metric version is measured in a cooling COP (Watt per Watt) similar to the traditional COP measurement.

Water Conditions Differences

Entering water temperatures have changed to reflect the centigrade temperature scale. For instance the water loop heating test is performed with 68°F (20°C) water rounded down from the old 70°F (21.1°C).

Air Conditions Differences

Entering air temperatures have also changed (rounded down) to reflect the centigrade temperature scale. For instance the cooling tests are performed with 80.6°F (27°C) dry bulb and 66.2°F (19°C) wet bulb entering air instead of the traditional 80°F (26.7°C) DB and 67°F (19.4°C) WB entering air temperatures. 80.6/66.2 data may be converted to 80/67 using the entering air correction table. This represents a significantly lower relative humidity than the old 80/67 of 50% and will result in lower latent capacities.

Pump Power Correction Calculation

Within each model, only one water flow rate is specified for all three groups and pumping Watts are calculated using the following formula. This additional power is added onto the existing power consumption.

- Pump power correction = (gpm x 0.0631) x (Press Drop x 2990) / 300

Where 'gpm' is waterflow in gpm and 'Press Drop' is the pressure drop through the unit heat exchanger at rated water flow in feet of head.

Blower Power Correction Calculation

Blower power is corrected to zero external static pressure using the following equation. The nominal airflow is rated at a specific external static pressure. This effectively reduces the power consumption of the unit and increases cooling capacity but decreases heating capacity. These Watts are significant enough in most cases to increase EER and COPs fairly dramatically over ARI 320, 325, and 330 ratings.

- Blower Power Correction = (cfm x 0.472) x (esp x 249) / 300

Where 'cfm' is airflow in cfm and 'esp' is the external static pressure at rated airflow in inches of water gauge.

ISO Capacity and Efficiency Calculations

The following equations illustrate cooling calculations:

- ISO Cooling Capacity = Cooling Capacity (Btuh) + (Blower Power Correction (Watts) x 3.412)
- ISO EER Efficiency (W/W) = ISO Cooling Capacity (Btuh) x 3.412 / [Power Input (Watts) - Blower Power Correction (Watts) + Pump Power Correction (Watt)]

The following equations illustrate heating calculations:

- ISO Heating Capacity = Heating Capacity (Btuh) - (Blower Power Correction (Watts) x 3.412)
- ISO COP Efficiency (W/W) = ISO Heating Capacity (Btuh) x 3.412 / [Power Input (Watts) - Blower Power Correction (Watts) + Pump Power Correction (Watt)]

Comparison of Test Conditions

	ARI 320	ISO/AHRI 13256-1 WLHP	ARI 325	ISO/AHRI 13256-1 GWHP	ARI 330	ISO/AHRI 13256-1 GLHP
Cooling						
Entering Air - DB/WB °F	80/67	80.6/66.2	80/67	80.6/66.2	80/67	80.6/66.2
Entering Water - °F	85	86	50/70	59	77	77
Fluid Flow Rate	*	**	**	**	**	**
Heating						
Entering Air - DB/WB °F	70	68	70	68	70	68
Entering Water - °F	70	68	50/70	50	32	32
Fluid Flow Rate	*	**	**	**	**	**

Note *: Flow rate is set by 10°F rise in standard cooling test
Part load entering water conditions not shown.

Note **: Flow rate is specified by the manufacturer

WLHP = Water Loop Heat Pump; GWHP = Ground Water Heat Pump; GLHP = Ground Loop Heat Pump

Conversions:

Airflow (lps) = CFM x 0.472;

ESP (Pascals) = ESP (in wg) x 249;

WaterFlow (lps) = GPM x 0.0631;

Press Drop (Pascals) = Press Drop (ft hd) x 2990

The Console

The G Series provides:

- Highest efficiencies and lowest operating costs
- Broadest R410A product line
- Standard or extended range (geothermal) operation
- Quiet operation
- Flexible control options

G Series Console Models

GCC 09-18 (3/4-1.5 tons) Chassis Only
 GCW 09-18 (3/4-1.5 tons) Flat top cabinet
 GCS 09-18 (3/4-1.5 tons) Slope top cabinet
 GCE 09-18 (3/4-1.5 tons) Extended Slope Top cabinet



High Efficiency

G Series is the highest efficiency units available. Large oversized air coils, water to refrigerant heat exchangers and rotary compressors provide extremely efficient operation. This efficiency means the G Series requires less loop than any product on the market. This can mean significant savings on commercial projects.

Quiet Operation

All G Series Console product is ARI 350 sound rated using third party sound testing. Room Noise Criteria Curves (NC Curve) may be calculated using data from the ARI 350 ratings giving the engineer total flexibility in assuring a quiet environment.

Standard Features

- Slope and Flat top configurations
- Extended cabinet options
- Footprint matches “legacy” products for easy retrofits.
- Attractive rounded corners heavy gauge cabinet.
- Quiet rotary compressors in all models.
- 2-dimension refrigerant piping vibration loops to isolate the compressor.
- All interior cabinet surfaces including the compressor compartment are insulated with 1/2” [12.7mm] thick
- 1-1/2lb [681g] density, surface coated, acoustic type glass fiber insulation.

Flexible Control Options

The **standard CCM** (compressor control module) is a more reliable replacement for electro-mechanical control applications. It features a small microprocessor board that handles the lockout function of the unit. A second microprocessor handles the unit mounted dial thermostat for maintaining accurate room temperature. Thermostat options include unit mounted or remote thermostat.

The **optional Versatec** microprocessor control board provides complete monitoring and control with optional field monitoring fault, status and I/O LED indication for easy servicing. The Versatec features a robust microprocessor control that monitors LP, HP, Condensate, field selectable thermistor freeze detection, while providing a flexible accessory relay and fault output scheme. Thermostat options include unit mounted or remote thermostat.

The **optional FX10** control provides unparalleled capability in several areas including performance monitoring, zoning, humidity, energy management, and service diagnosis, and then communicates it all thru standard DDC protocols like N2, Lon and BACnet (MS/TP @ 19,200 Baud rate).

The most unique feature is integrating the FX10 into the G Series as both the heat pump and DDC controller providing both a cost advantage and features not typically found on WLHP controls. This integration allows heat pump monitoring sensors, status and service diagnosis faults to be communicated thru the DDC direct to the building automation system (BAS), giving building supervisors detailed and accurate information on every piece of equipment without removing an access panel. Thermostat options include unit mounted sensor or remote sensor or remote thermostat.



CCM

VERSATEC

FX10

Optional user interface for diagnostics & commissioning of FX controls.



The Console cont.

Easy Maintenance and Service Advantages

- 2 removable compressor access panels
- Separate air handler and compressor section access panels permit service testing without bypass.
- Easy access to low voltage connector for easy thermostat wiring (remote & thermostat option).
- Quick attach wiring harnesses are used throughout for fast servicing.
- High and low pressure refrigerant service ports.
- Internal slide out blowers.

Factory Quality

- All refrigerant brazing is performed in a nitrogen environment.
- Computer controlled deep vacuum and refrigerant charging system.
- All joints are leak detected for maximum leak rate of less than 1/4 oz. per year.
- Computer bar code equipped assembly line insures all components are correct.
- All units are computer run-tested with water to verify both function and performance.

Inside the Console

Refrigerant

G Series products all feature zero ozone depletion and low global warming potential refrigerant R-410A.

Cabinet

All units are all constructed of corrosion resistant galvanized sheet metal with white polyester powder coat paint rated for more than 1000 hours of salt spray. Refrigerant circuit is designed to allow primary serviceability from the front. One access panel allows servicing of the blower motor, blower, and drain pan. Cabinet is designed to match "industry" foot print for ease of replacement.

Drain Pan

All condensate connections are welded stainless steel tubes for economical corrosion free connections. Bacteria resistant stainless steel drain pan is designed to promote complete drainage and will never rust or corrode. Complete drainage helps to inhibit bacterial or microbial growth. Units feature an internally trapped condensate line.

Compressors

High efficiency R-410A rotary compressors are used on every model. Rotary compressors (available in 208-230V & 265V 60Hz Single Phase) provide both the highest efficiency available and great reliability.

Electrical Box

Unit controls feature quick connect wiring harnesses for easy servicing. Large 75VA transformer assures adequate controls power for accessories.

Thermostatic Expansion Valve

All G Series models utilize a balanced port bi-directional thermostatic expansion valve (TXV) for refrigerant metering. This allows precise refrigerant flow in a wide range of entering water variation (20 to 120°F [-7 to 49 °C]) found in geothermal systems.



Water to Refrigerant Coaxial Heat Exchanger Coil

Large oversized coaxial refrigerant to water heat exchangers provide unparalleled efficiency. The coaxes are designed for low pressure drop and low flow rates. All coaxes are pressure rated to 450 psi water side and 600 psi on the refrigerant side. Optional ThermaShield coated water-to-refrigerant coaxial heat exchanger is available to prevent condensation in low temperature loop operation.



Service Connections and Serviceability

Two Schrader service ports are provided in every unit. The suction side and discharge side ports are for field charging and servicing access. All valves are 7/16" SAE connections. All water and electrical connections are made from the front of the unit. Unit is designed for front access serviceability.



4-Way Reversing Valve

G Series units feature a reliable all-brass pilot operated refrigerant reversing valve. The reversing valve operation is limited to change of mode by the control to enhance reliability. (Versatec and FX10 Only).









Air Coil

Large low velocity air coils are constructed of lanced fin and ruffled tube. Each model features 3 - 4 rows for added moisture removal. An optional FormiShield™ air coil coating is available to further inhibit formicary corrosion.

Blower Motor and Housing

High efficiency low rpm galvanized direct drive blowers featuring 2 speed permanently split capacitor (PSC) motor. All PSC motors have speed selection switch on the control cover for easy speed change. All motors are vibration isolated to reduce noise.

Controls

Control	General Description	Application	Display/Interface	Protocol	Thermostat Options
CCM Control 	The CCM (Compressor control module) is a more reliable replacement for electro-mechanical control applications. It features a small microprocessor board that handles the lockout function of the unit. A second microprocessor handles the unit mounted thermostat for maintaining accurate room temperature.	Residential and commercial applications requiring minimal but reliable controls. Includes Random Start, High and low pressure switches and auto changeover capability.	Dial thermostat with Hi and Low blower speeds, and auto changeover or cont blower selection switches.	None	Unit Mounted Digital Dial Thermostat
					Remote Mounted Standard Thermostat
Versatec Control 	The Versatec Control is a microprocessor based board that adds the features of emergency shutdown (ES), night setback (NS), water freeze detection (FS), Load Shed (LS) and condensate overflow (CO). The Versatec Control also features Optional Field servicing LED's for mode, Fault and diagnostic indication.	Residential and commercial applications requiring more controls features than CCM and Includes Random Start, High and low pressure switches, auto changeover capability, emergency shutdown (ES), night setback (NS), load shed (LS), water freeze detection (FS), and condensate overflow (CO).	Optional field servicing LED board for mode, fault and diagnostic indication	None	Unit Mounted Digital Dial Thermostat
					Remote Mounted Standard Thermostat
FX10 	The FX10 microprocessor control is self contained control featuring LP, LOC, HP, LWT, and condensate overflow fault modes can be displayed on BAS system. Optional handheld Medium User Interface (MUI) Control can be used for additional setup or servicing. Program customization is possible. This control is suited for both single and dual capacity compressors as well as PSC and ECM blower motors.	Commercial applications using single and dual capacity compressors with either PSC or ECM blower motors. Also suitable for multi-compressor products. Cannot be integrated with centralized building automation systems. Software can be customized for specific projects.	Optional Medium User Interface (MUI) can be used as a field service tool.	Standalone	Unit Mounted Digital Dial Sensor
					Remote Mounted Standard Thermostat
					Remote Mounted Sensor
FX10 w/ N2 	FX10 Control functions as both unitary heat pump control and DDC communication, therefore detail operational and fault information is available to BAS. Other features are same as FX10 with addition of Johnson Controls N2 compatibility.	Same as FX10 with Johnson Controls N2 BAS compatibility.	Optional Medium User Interface (MUI) can be used as a field service tool.	Johnson Controls N2 network	Unit Mounted Digital Dial Sensor
					Remote Mounted Standard Thermostat
					Remote Mounted Sensor
FX10 w/ LonWorks 	FX10 Control functions as both unitary heat pump control and DDC communication, therefore detail operational and fault information is available to BAS. Other features are same as FX10 with addition of LonWorks compatibility.	Same as FX10 with LonWorks BAS compatibility.	Optional Medium User Interface (MUI) can be used as a field service tool.	LonWorks	Unit Mounted Digital Dial Sensor
					Remote Mounted Standard Thermostat
					Remote Mounted Sensor
FX10 w/ BACnet 	FX10 Control functions as both unitary heat pump control and DDC communication, therefore detail operational and fault information is available to BAS. Other features are same as FX10 with addition of BACnet compatibility.	Same as FX10 with BACnet BAS compatibility. Due to communication speed, no more than 30 units should be connected to a single trunk of the network.	Optional Medium User Interface (MUI) can be mounted or used as a field service tool.	BACnet - MS/TP (19,200 Baud Rate)	Unit Mounted Digital Dial Sensor
		Remote Mounted Standard Thermostat			
		Remote Mounted Sensor			

Standard CCM Control Features

Compressor control module (CCM) controls are standard on the G Series console heat pump. This control features unit mounted thermostat and switches,

Features of the standard control are:

- Easy to understand color coded thermostat adjustment markings.
- Large, rocker type mode and blower switches.
- Internally mounted blower switch to choose cycled or constant blower operation.

- High pressure and low pressure safety controls to protect the unit components.
- Lockout circuit to shut down unit operation upon receipt of a fault indicator from the safety controls.
- A 24 volt control circuit allows for safe and easy diagnosis.

Controls cont.

The user selects either “Heat/Cool” or “Fan Only” on the mode switch, then either “High” or “Low” at the blower speed switch. The temperature can be controlled by rotating the thermostat control

Figure 6: Unit Mounted Control

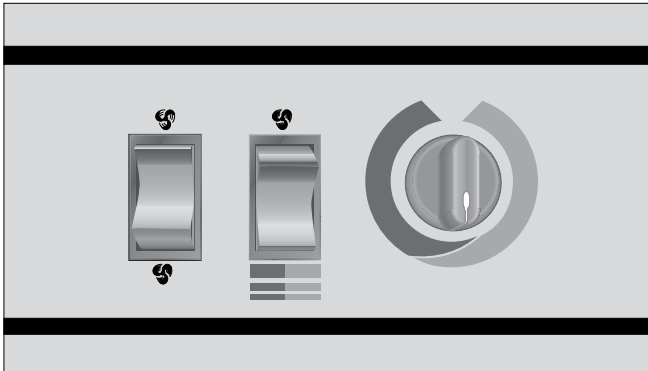

knob.

The “Fan Only” setting provides constant blower operation.

In the “Heat” mode, a call for heat by the thermostat closes the compressor contactor contacts, energizing the compressor, which will run until the thermostat is satisfied.

In the “Cool” mode, a call for cooling by the thermostat energizes the reversing valve and closes the compressor contactor contacts, energizing the compressor, which will run until the thermostat is satisfied.

The emergency electric heat operation in the “Heat/Cool” mode is subject to the setting of the internally mounted mode switch. The optional, factory installed electric heat will operate when the internally mounted mode switch is in the “Emergency Heat” mode. In the “Heat” mode, a call for heating energizes the blower and electric heater contactor, energizing the electric heat elements and blower, which will run until the thermostat is satisfied. When the internally mounted mode switch is in the “Normal/Boilerless” mode the unit operates in its normal “Heat/Cool” operation, unless there is an aquastat controller. When the normally open circuit of the aquastat closes and the unit is in the heating mode, it will switch to the “Emergency Heat” condition until the thermostat is satisfied or the aquastat opens restarting the compressor.

If either the low or high pressure safety switches are opened, the compressor and reversing valve are disabled by the lockout relay. Unit operation will resume only after the voltage to the unit is interrupted or the mode switch is placed in the “Off” position.

If the electric heat limit switches are opened, the electric heat is disabled.

Optional Versatec Microprocessor Control Features

The Versatec microprocessor board provides control of the entire

unit as well as outputs for status modes, faults and diagnostics.

The control system is a microprocessor-based control board that is located in the unit control box. This feature is available for either unit mounted controls or optional remote wall mounted thermostat. A 9-pin low voltage terminal strip provides all necessary terminals for the wall mounted thermostat.

Startup

The unit will not operate until all the inputs and safety controls are checked for normal operating conditions.

Fault Retry

All faults are retried twice before finally locking the unit out to prevent nuisance service calls.

Component Sequencing Delays

Components are sequenced and delayed for optimum unit performance.

Short Cycle Protection and Random Start

The control allows a minimum on or off time of 5 minutes for short cycle protection. A random time delay of 0 to 30 seconds is generated after each power-up to prevent simultaneous start up of all units within a building after the release from an unoccupied cycle or power loss.

Night Setback

A grounded signal to common or connecting 24 VAC to the NS terminal will initiate the night setback mode.

Load Shed

A grounded signal to common or connecting 24 VAC to the LS terminal places the controller into the load shed mode. The compressor will become disabled and the blower will start upon a thermostat call for heating or cooling.

Emergency Shutdown

A grounded signal to common or connecting 24 VAC to the ES terminal places the controller into the emergency shutdown mode. The compressor and blower operation are suspended while in the emergency shutdown mode.

Condensate Overflow Protection

The board incorporates an impedance liquid sensor at the top of the condensate drain pan. Upon a continuous 30-second sensing of the condensate, the cooling operation of the unit is suspended.

Safety Controls

The microprocessor board receives separate signals from a high pressure switch for safety, a low pressure switch to prevent loss of refrigerant charge and a low suction temperature thermistor for freeze detection. Upon a continuous 30-second measurement of the fault (immediate for high pressure), compressor operation is stopped.

Controls cont.

Control Tables for Optional Versatec Microprocessor

Logic Board DIP Switch Settings

Switch	OFF	ON
SW1 - 1	Test - Selected timings sped up to facilitate troubleshooting	Normal - Standard timings
SW1 - 2	Loop - Closed loop freeze detection setting (15°F)	Well - Open loop freeze detection setting (30°F)
SW1 - 3	Commercial - Enables NS features when TA32U02 thermostat is used	Normal - Standard thermostat operation
SW1 - 4	IO Display* - Enables Input/Output display on external LED board	Normal* - Unit status display
SW1 - 5	Configures board for 2-speed compressor without blower	Configures board for 2-speed compressor with blower

Normal Control Timing

Blower off delay	30 seconds
Compressor on delay	10 seconds
Short cycle delay	5 minutes
Minimum compressor on time	2 minutes (except for fault condition)
High pressure fault recognition delay	Less than 1 second
Low pressure fault recognition delay	30 seconds
Freeze detection fault recognition delay	30 seconds
Condensate overflow fault recognition delay	30 seconds
Low pressure fault bypass delay	2 minutes
Freeze detection fault bypass delay	2 minutes
Power on delay	5 minutes

Operational Logic

Mode	Inputs	Blower	Comp	RV
Htg	Y	ON	ON	OFF
Clg	Y,O	ON	ON	ON
Blower	G	ON	OFF	OFF

Test Control Timing

Blower off delay	5 seconds
Compressor on delay	2 seconds
Short cycle delay	15 seconds
Minimum compressor on time	5 seconds (except for fault condition)
High pressure fault recognition delay	Less than 1 second
Low pressure fault recognition delay	30 seconds
Freeze detection fault recognition delay	30 seconds
Condensate overflow fault recognition delay	30 seconds
Low pressure fault bypass delay	0 seconds
Freeze detection fault bypass delay	0 seconds
Power on delay	15 seconds
Fault off time	5 minutes

Diagnostic Modes

LED	Current Fault Status SW1 - #4 On, SW2 On	Inputs SW1 - #4 Off, SW2 Off	Outputs SW1 - #4 Off, SW2 On
Drain	Drain pan overflow	Y	Compressor
Water Flow	FS thermistor (loop <15°F, well <30°F)	G	Blower
High Press	High pressure >600 PSI	O	O
Low Press	Low pressure <40 PSI	ES	ES
Air Flow	Not used	NS	NS
Status	Not used	LS	LS
DHW Limit	Not used	Not used	Not used
HWD	SW2 in the On position	Off position	On position

Controls - FX10 (optional)

Optional FX10 Control



The optional FX10 control provides unparalleled capability in several areas including performance monitoring, zoning, humidity, energy management, and service diagnosis, and then communicates it all thru standard DDC protocols like N2, Lon and BACnet (MS/TP @ 19,200 Baud rate).

The most unique feature is integrating the FX10 into the G Series as both the heat pump and DDC controller providing both a cost advantage and providing features not typically found on WLHP controls. This integration allows heat pump monitoring sensors, status and service diagnosis faults to be communicated thru the DDC direct to the building automation system (BAS), giving building supervisors detailed and accurate information on every piece of equipment without removing an access panel.

FX10 Advanced Control Overview

The Johnson Controls FX10 board is specifically designed for commercial heat pumps and provides control of the entire unit as well as input ports for Open N2, LonTalk, BACnet (MS/TP @ 19,200 Baud rate) communication protocols as well as an input port for a user interface. The user interface is an accessory item that can be used to aid in diagnostics and unit setup. A 16-pin low voltage terminal board provides terminals for common field connections. The FX10 Control provides:

- Operational sequencing
- High and low-pressure switch monitoring
- General lockout
- Freeze detection
- Condensate overflow sensing
- Lockout mode control
- Emergency shutdown mode
- Random start and short cycle protection

Short Cycle Protection

Allows a minimum compressor “off” time of four minutes and a minimum “on” time of two minutes.

Random Start

A delay of 1 to 120 seconds is generated after each power-up to prevent simultaneous startup of all units within a building after the release from an unoccupied cycle or power loss.

Emergency Shutdown

A field-applied dry contact can be used to place the control into emergency shutdown mode. During this mode, all outputs on the board are disabled.

Freezed Detection Limit

Field selectable for 15° or 30°F (-9° or -1°C)

Installation Options

- Standalone controlled by standard room thermostat
- Standalone with a Zone Temperature Sensor (must have user interface to change set points beyond the allowed +/- 5°F)
- Integrated into BAS by adding communication module

Accessory Outputs

Quantity 2. One cycled with blower, other with compressor.

User Interface

4 x 20 backlit LCD.

Optional Plug-in Communication Modules - (compatible with standard BAS protocols)

- Open N2
- LonTalk
- BACnet (MS/TP @ 19,200 Baud rate)

Display

Requires DLI Card/Kit. Up to 2 displays, either 1 local and 1 remote, or 2 remote. (A 2-display configuration requires identical displays.) Local display can be up to 3 meters from the controller, power supply, and data communication. Remote display can be up to 300 meters from the controller. Remote display must be independently powered with data communication done via 3 pole shielded cable.

Control Timing & Fault Recognition Delays

Lead compressor “ON” delay	90 seconds
(not applicable for single compressor models)	
Minimum compressor “ON” time.....	2 minutes
(except for fault condition)	
Short cycle delay	5 minutes
Random start delay	0-120 seconds
High pressure fault	<1 second
Low pressure fault	30 seconds
Freeze detection fault	30 seconds
Condensate overflow fault.....	30 seconds
Low pressure fault bypass.....	2 minutes
Freeze detection fault bypass.....	2 minutes

Optional FX10 Microprocessor and BAS Interface

The FX10 is a microprocessor based control that not only monitors and controls the heat pump but also can communicate any of this information back to the building automation system (BAS). This means that not only does the control monitor the heat pump at the unit you can also monitor and control many the features over the BAS. This clearly puts the FX10 in a class of its own.

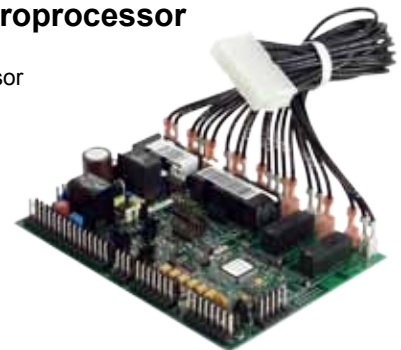

Controls - FX10 cont.

The control will enumerate all fault conditions (HP, LP, CO, LOC, and freeze detection) over a BAS as well as display them on a medium user interface (MUI). HP, LP, CO and freeze detection faults can all be reset over a BAS. A Loss Of Charge fault can not be reset or bypassed until the problem has been corrected. A MUI is invaluable as a service tool for the building service team.

The unit can be commanded to run by a typical heat pump thermostat or run based on heating and cooling set points supplied by a BAS. The control board is wired with quick connect harnesses for easy field change out of a bad control board. All ECM2.3 variable blower speed settings can be changed over a BAS or with a MUI. The control has an input programmed to enable field installed emergency heat in the event that the compressor is locked out. This input can also be commanded on from a BAS as needed. An alarm history can be viewed through the MUI and will be held in memory until the unit is power cycled. Relative humidity can be read by a 0-5VDC humidity sensor that is displayed over the network. If you are using an ECM2.3 blower motor the control can enable dehumidification mode based on a set point in the control. The dehumidification set point itself can also be changed over a BAS or with a MUI. Dehumidification mode can also be enabled by the BAS. Because the FX10 is not factory configured to read CO² levels, contact the factory for application assistance.

The FX10 control has unused analog and digital inputs for field installed items such as air temperature, water temperature, CO² or current status switches. The control has unused binary and PWM outputs that can be commanded over the BAS for field use. An optional Medium User Interface (MUI) for control setup and advanced diagnostics is available with some mounting kits, MUIK1 - Panel mount version and the MUIK2-Wall mount version.

Zone Sensors

There are two options for zone sensors that can be used with the FX10 control. Both sensors use a Johnson controls A99 positive temperature coefficient type sensor. The TAXXJ02 has a set point adjustment now which will give the end user a +/- 5°F adjustment from the set point as well as a push button that can be used for temporary occupancy. The control leaves the factory set to operate with a TAXXJ02 sensor and can be changed to read the TAXXA01 sensor through a building automation system or with a user interface.

Standard Features

- Anti Short Cycle
- High Pressure Protection
- Low Pressure Protection
- Freeze Detection
- Loss Of Charge Detection
- Random Start
- Display for diagnostics
- Reset Lockout at disconnect or through BAS
- 2 Accessory outputs
- Optional BAS add-on controls

DDC Operation & Connection

Other optional network protocol boards that can be added to FX10:

- Johnson Control N2
- LonWorks
- BACnet
 - MS/TP @ 19,200 Baud rate
 - Limit devices to 40 on a single trunk line.

Control and Safety Feature Details Emergency Shutdown

The emergency shutdown mode can be activated by a command from a facility management system or a closed contact on BI-2. The default state for the emergency shutdown data point is off. When the emergency shutdown mode is activated, all outputs will be turned off immediately and will remain off until the emergency shutdown mode is de-activated. The first time the compressor starts after the emergency shutdown mode has been de-activated, there will be a random start delay present.

Lockout Mode

Lockout mode can be activated by any of the following fault signals: refrigerant system high pressure, refrigerant system low pressure, freeze detection, and condensate overflow. When any valid fault signal remains continuously active for the length of its recognition delay, the controller will go into fault retry mode, which will turn off the compressor. After the Compressor short cycle delay, the compressor will attempt to operate once again. If three consecutive faults occur in 60 minutes during a single heating or cooling demand, the unit will go into lockout mode, turning off the compressor, enabling the alarm output, and setting the blower back to low speed operation until the controller is reset. If the control faults due to the low pressure input (BI-3) being open during the pre-compressor startup check, the control will go into lockout mode immediately, disabling the compressor from starting and enabling the alarm output (BO-6). The lockout condition can be reset by powering down the controller, by a command from the BAS, or by the holding the ESC and Return keys on the MUI for 5 seconds.

Freeze Detection Limit (AI-5)

The freeze detection limit sensor will monitor the liquid refrigerant temperature entering the water coil in the heating mode. If the temperature drops below the freeze detection limit trip point for the recognition delay period, the condition will be recognized as a fault. The freeze detection limit trip point will be factory set for 30°F and will be field selectable for 15°F by removing a jumper wire on BI-5. The freeze detection limit fault condition will be bypassed 2 minutes at normal compressor startup, to allow the refrigeration circuit to stabilize. If the freeze detection limit sensor becomes unreliable at any time compressor operation will immediately be suspended until the problem is corrected. This should be displayed as an alarm on the BAS and the MUI. This alarm will be reported a "Water Low Temp Limit" fault.

High Pressure (BI-11)

The high-pressure switch shall be a normally closed (NC) switch that monitors the systems refrigerant pressure. If the input senses the high-pressure switch is open it must disable the compressor output immediately and count the fault. The compressor minimum on time does not apply if the high-pressure switch opens. The compressor will not restart until the compressor short cycle time delay has been satisfied.

Low Pressure (BI-3)

The low-pressure switch shall be a normally closed (NC) switch that monitors the systems refrigerant pressure. The input shall be checked 15 seconds before compressor start up to be sure the pressure switch is closed and then ignored for the first 2 minutes after the compressor output (BO-2) is enabled. If the switch is open continuously for (30) seconds during compressor operation the compressor output (BO-2) will be disabled. The compressor will not restart until the compressor short cycle time delay has been satisfied.

Controls - FX10 cont.

Condensate Overflow

The condensate overflow sensing circuit will monitor the condensate level as a resistance input to AI-3. If the condensate water level rises resulting in the input resistance rising above the set point for the recognition delay period, the condition will be recognized as a fault. The condensate will be subjected to a (30) second lockout delay which requires that the fault be sensed for a continuous (30) seconds before suspending unit operation.

Alarm Output (BO-6)

The alarm output will be enabled when the control is in the lockout mode and will be disabled when the lockout is reset.

Test Mode

Raising the zone temperature input (AI-1) reading to 180–220°F or by holding the ESC and down arrow keys on the MUI for 5 seconds will put the control into test mode. In test mode the random start delay and the compressor fixed on delay time will both be shortened to 5 seconds and the reversing valve will be allowed to cycle without shutting down the compressor. If an MUI is connected to the control LED 8 will flash and the words "Test Mode Enabled" will be shown on the LCD display when the control is in test mode. Test mode will be disabled after a power cycle, 30 minute timeout, or by holding the ESC and Up arrow keys on the MUI.

Sequence of Operation

Power Fail Restart

When the controller is first powered up, the outputs will be disabled for a random start delay. The delay is provided to prevent simultaneous starting of multiple heat pumps. Once the timer expires, the controller will operate normally.

Random Start Delay

This delay will be used after every power failure, as well as the first time the compressor is started after the control exits the unoccupied mode or the emergency shutdown mode. The delay should not be less than 1 second and not longer than 120 seconds. If the control is in test mode the random start delay will be shortened to 5 seconds.

Compressor Fixed On Delay Time

The Compressor Fixed On Delay Time will ensure that the compressor output (BO2) is not enabled for (90) seconds after the control receives a call to start the compressor. This delay is adjustable from 30 – 300 seconds over a BAS or a MUI. If the control is in test mode the Compressor Fixed On Delay Timer will be shortened to 5 seconds.

Compressor Minimum On Delay

The compressor minimum on delay will ensure that the compressor output is enabled for a minimum of (2) minute each time the compressor output is enabled. This will apply in every instance except in the event the high pressure switch is tripped or emergency shutdown then the compressor output will be disabled immediately.



Compressor Short Cycle Delay Time

The compressor short cycle time delay will ensure that the compressor output will not be enabled for a minimum of (5) minutes after it is disabled. This allows for the system refrigerant pressures to equalize after the compressor is disabled.

Heating Cycle

On a call for heating, the blower enable output and accessory output 2 will turn on immediately after the random start delay timer has been satisfied. If the compressor short cycle time delay has been satisfied, the compressor will turn on after the blower enable and accessory output 2 are on and the fixed compressor start delay timers have been satisfied.

Auxiliary heat output can be controlled over the BAS.

Set Point Control Mode

In set point control mode the reversing valve output will be disabled. As the temperature drops below the heating set point and begins to operate in the heating proportional band, the low capacity compressor output (BO-2) will be enabled. A PI loop in the programming of the control will determine when the full capacity compressor output (BO-4) is to be enabled. The compressor must be operating in low capacity for a minimum of 30 seconds before the full capacity compressor output can be enabled. During low capacity compressor operation the ECM2.3 blower will operate in medium speed and will operate in high speed when the compressor is operating at full capacity.

Thermostat Control Mode

In thermostat mode the compressor will be cycled based on Y1 and Y2 calls from a room thermostat. When the control receives a Y1 command (BI-7) from the thermostat the low capacity compressor output (BO2) will be enabled and the ECM2.3 blower will operate in medium speed. When the control receives a Y2 command (BI-8) from the thermostat the full capacity compressor output will be enabled and the ECM2.3 blower will operate in high speed. During the heating cycle the reversing valve will be commanded into the off position.

Cooling Cycle

On a call for cooling, the blower enable output and accessory output 2 will turn on immediately after the random start delay timer has been satisfied. If the compressor short cycle time delay has been satisfied, the compressor will turn on after the blower enable and accessory output 2 are on and the fixed compressor start delay timers have been satisfied.

Set Point Control Mode

In set point control mode the reversing valve output will be enabled. As the temperature falls below the cooling set point and begins to operate in the cooling proportional band, the low capacity compressor output (BO-2) will be enabled. A PI loop in the programming of the control will determine when the full capacity compressor output (BO-4) is to be enabled. The compressor must be operating in low capacity for a minimum of 30 seconds before the full capacity compressor output can be enabled. During low capacity compressor operation the ECM2.3 blower will operate in medium speed and will operate in high speed when the compressor is operating at full capacity.

Controls - FX10 cont.

Thermostat Control Mode

In thermostat mode the compressor will be cycled based on Y1 and Y2 calls from a room thermostat. When the control receives a Y1 command (BI-7) from the thermostat the low capacity compressor output (BO2) will be enabled and the ECM2.3 blower will operate in medium speed. When the control receives a Y2 command (BI-8) from the thermostat the full capacity compressor output will be enabled and the ECM2.3 blower will operate in high speed. During the cooling cycle the reversing valve will be commanded into the "ON" position.

ECM2.3 Blower Operation

Blower speeds will be selected through the user interface or the facility management system. There will be a total of 12 speeds selectable with only three being selected at any one time. The lowest numbered speed selection set to ON will select the low-speed blower setting, the middle selection set to ON will select the medium-speed blower setting and the highest selection set to ON will select the high-speed blower setting. If all selections are set to OFF the software shall select speed setting 10 for low-speed, 11 for medium-speed, and will select speed setting 12 for high speed. If only one selection is set to ON, that selection will set the low-speed blower setting, the medium-speed setting will be 11, and the high-speed setting will be speed 12. The maximum low-speed setting will be speed 10 and the minimum high-speed setting will be speed 3. In addition there is a low limit setting in the software to prevent the ECM2.3 blower speed from being set below acceptable limits for each unit size.

ECM2.3 Blower air flow "Soft Switch Settings"

A set of 12 "soft switches" accessible through the user interface or building automation system are used to select the three blower speed settings for the ECM2.3 blower motor. The 12 soft switches work in exactly the same way as the hardware switches used on the Premier control (Refer to Blower Performance Data - ECM2.3 Motor for proper settings). No more than three soft switches may be set to the "ON" position. The first "ON" switch (the lowest number switch) determines the "low speed fan" setting. The second determines the "medium speed fan" setting, and the third determines the "high speed fan" setting.

Emergency Heat/Network Enabled Output (BO5)

This output is set from the factory to enable/disable emergency heat. If a problem occurs with the unit resulting in the compressor being locked out in heating mode, the control will automatically enable this output to turn on field installed electric heat. This output is interlocked with the blower proving input BI-6 (Blower proving sensors must be field supplied and installed). BI-6 must be connected to PB2 position 3 (see unit schematic) in the field if no blower proving sensor is desired. There is a configurable parameter available through a BAS network that must be enabled if this output is to be commanded over the BAS network.

MUI Alarm History Reporting

If a fault occurs the fault will be recorded in history for display on the medium user interface in the History Menu. Each fault type will be displayed in the history menu with a number between 0 and 3. A reading of 3+ will mean that fault has occurred more than three times in the past. The history menu can be cleared with a power cycle only. Alarm date and time are not included in the history.

Inputs & Outputs Configuration Field Selectable Options

Freeze Detection Limit Set Point (BI-5)

The freeze detection limit set point input allows you to adjust the freeze detection limit set point (AI-5). When the jumper is installed on BI-5 (Wire #24) the freeze detection limit set point is factory set for 30°F. When the jumper on BI-5 (Wire #24) is removed the freeze detection limit set point will be 15°F.

Accessory Outputs (BO-7 and BO-8)

Accessory Output 1 will be energized 90 seconds prior to the compressor output being energized. Accessory Output 2 will be energized with the blower output (BO-1). When the corresponding compressor output is turned off the accessory output will be deactivated immediately. These outputs are selectable for normally open or normally closed operation through the Medium User interface or through the Building Automation System.

Control Accessories

Zone Sensors

- TAXXJ02 Room Command Module
- TAXXA01 LCD Room Command Module
- A99 Sensor

MUI (LCD User interface) for diagnostics and commissioning.

- MUIK3 - Panel Mount, Portable
- MUIK4 - Wall Mount

SINGLE and DUAL STAGE WATER-TO-AIR			
Input Name	Input	Output Name	Output
Zone Temp 1	AI 1	Fan Enable	BO1
Relative Humidity Input	AI 2	Comp - Low Capacity	BO2
Condensate Level	AI 3	Reversing Valve	BO3
Universal Temp Input	AI 4	Comp - Full Capacity	BO4
Water Coil Low Temperature Limit	AI 5	Network Output/EH Output	BO5
Warm/Cool Adjust and Temp Occ	AI 6	Alarm	BO6
		Accessory 1 Output	BO7
Occupied	BI 1	Accessory 2 Output	BO8
Emergency Shutdown	BI 2	Network Controlled Output	BO9
Stage 1 Low Pressure	BI 3		
Network Viewable Input 1	BI 4	ECM2 Fan	PWM1
Water Coil Low Temp Limit Set Point	BI 5	Network Controlled Output	PWM2
Network Viewable Input 2	BI 6		
Thermostat Y1	BI 7		
Thermostat Y2	BI 8		
Thermostat O	BI 9		
Thermostat G	B10		
Stage 1 High Pressure	BI11		
Compressor Proving	BI12		
XP10 Expansion Card			
Input Name	Input	Output Name	Output
Unused	AI 1	Unused	BO 1
Unused	AI 2	Unused	BO 2
Unused	AI 3	Unused	BO 3
Unused	AI 4	Unused	BO 4

Application Notes

The Closed Loop Heat Pump Concept

The basic principle of a water source heat pump is the transfer of heat into water from the space during cooling, or the transfer of heat from water into the space during heating. Extremely high levels of energy efficiency are achieved as electricity is used only to move heat, not to produce it. Using a typical G Series, one unit of electricity will move four to five units of heat.

When multiple water source heat pumps are combined on a common circulating loop, the ultimate in energy efficiency is created: Units on cooling mode are adding heat to the loop which the units in heating mode can absorb, thus removing heat from the area where cooling is needed, recovering and redistributing that heat for possible utilization elsewhere in the system. In modern commercial structures, this characteristic of heat recovery from core area heat generated by lighting, office equipment, computers, solar radiation, people or other sources, is an important factor in the high efficiency and low operating costs of closed source heat pump systems.

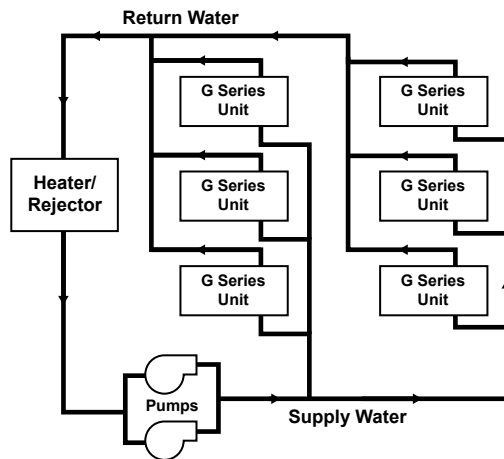

In the event that a building's net heating and cooling requirements create loop temperature extremes, G Series units have the extended range capacity and versatility to maintain a comfortable environment for all building areas. Excess heat can be stored for later utilization or be added or removed in one of three ways; by ground-source heat exchanger loops: plate heat exchangers connected to other water sources, or conventional cooler/boiler configurations. Your representative has the expertise and computer software to assist in determining optimum system type for specific applications.

The Closed Loop Advantage

A properly applied water source heat pump system offers many advantages over other systems. First costs are low because units can be added to the loop on an "as needed basis" - perfect for speculative buildings. Installed costs are low since units are self-contained and can be located adjacent to the occupied space, requiring minimal ductwork. Maintenance can be done on individual units without system shut-down. Conditions remain

comfortable since each unit operates separately, allowing cooling in one area and heating in another. Tenant spaces can be finished and added as needed. Power billing to tenants is also convenient since each unit can be individually metered: each pays for what each uses. Nighttime and/or weekend uses of certain areas are possible without heating or cooling the entire facility. A decentralized system also means if one unit should fault, the rest of the system will continue to operate normally, as well as eliminating air cross-contamination problems and expensive high pressure duct systems requiring an inefficient electric resistance reheat mode.

The G Series Approach

There are a number of proven choices in the type of G Series system which would be best for any given application. Most often considered are:

Vertical - Closed Loop/Ground Source

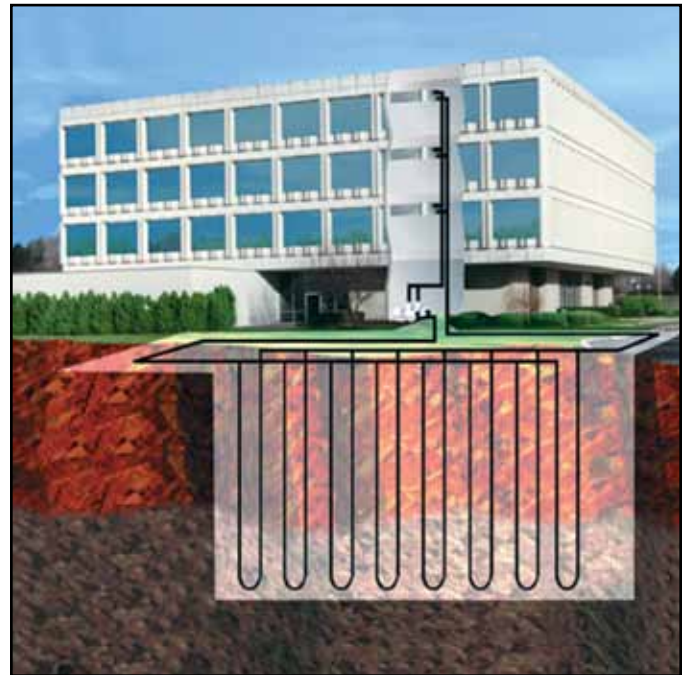

• **Closed Loop/Ground-Source Systems** utilize the stable temperatures of the earth to maintain proper water source temperatures (via vertical or horizontal closed loop heat exchangers) for G Series extended range heat pump system. Sizes range from a single unit through many hundreds of units. When net cooling requirements cause closed loop water temperatures to rise, heat is dissipated into the cooler earth through buried high strength plastic pipe "heat exchangers." Conversely if net space heating demands cause loop heat absorption beyond that heat recovered from building core areas, the loop temperature will fall causing heat to be extracted from the earth. Due to the extended loop temperatures, AHRI/ISO 13256-1 Ground Loop Heat Pumps are required for this application. Because auxiliary equipment such as a fossil fuel boiler and

Application Notes cont.

cooling tower are not required to maintain the loop temperature, operating and maintenance costs are very low.

Ground-source systems are most applicable in residential and light commercial buildings where both heating and cooling are desired, and on larger envelope dominated structures where core heat recovery will not meet overall heating loads. Both vertical and horizontally installed closed-loops can be used. The land space required for the "heat exchangers" is 100-250 sq. ft./ton on vertical (drilled) installations and 750-1500 sq. ft./ton for horizontal (trenched) installations. Closed loop heat exchangers can be located under parking areas or even under the building itself.

On large multi-unit systems, sizing the closed loop heat exchanger to meet only the net heating loads and assisting cooling loads with a closed circuit cooling tower may be the most cost effective choice.

Surface Water - Closed Loop/Ground Source



• **Closed Loop/Ground-Source Surface Water Systems** also utilize the stable temperatures of Surface Water to maintain proper water source temperatures for G Series extended range heat pump systems. These systems have all of the advantages of horizontal and vertical closed loop systems. Due to the extended loop temperatures, AHRI/ISO 13256-1 Ground Water or Ground Loop Heat Pumps are required for this application.

In cooling dominated structures, the ground-source surface water systems can be very cost effective especially where local building codes require water retention ponds for short term storage of surface run-off. Sizing requirements for the surface water is a minimum of 500 sq. ft./ton of surface area at a minimum depth of 8 feet. WaterFumace should be contacted when designs for heating dominated structures are required.

Plate Heat Exchanger - Closed Loop/Ground Water

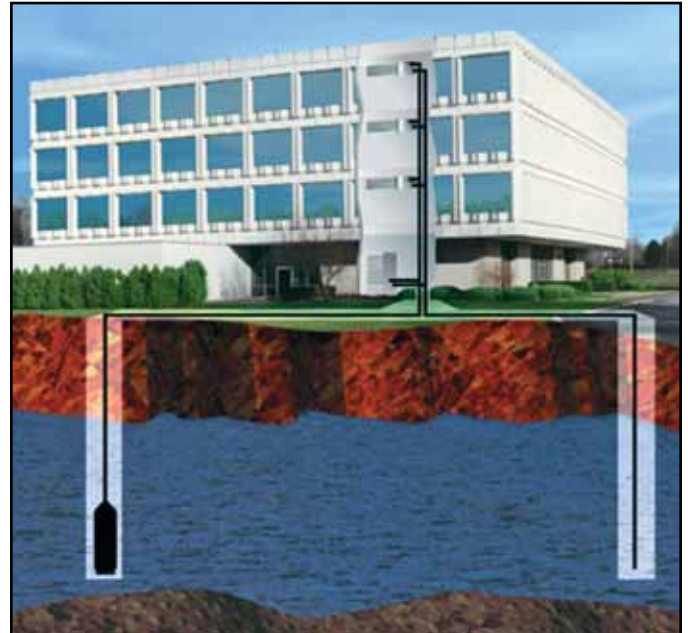

• **Closed Loop/Ground Water Plate Heat Exchanger Systems** utilize lake, ocean, well water or other water sources to maintain closed loop water temperatures in multi-unit G Series systems. A plate frame heat exchanger isolates the units from any contaminating effects of the water source, and allows periodic cleaning of the heat exchanger during off peak hours.

Operation and benefits are similar to those for ground-source systems. Due to the extended loop temperatures, AHRI/ISO 13256-1 Ground Loop Heat Pumps are required for this application. Closed loop plate heat exchanger systems are applicable in commercial, marine, or industrial structures where the many benefits of a water source heat pump system are desired, regardless of whether the load is heating or cooling dominated.

Application Notes cont.

Cooler/Boiler - Closed Loop



• **Closed Loop /Cooler-Boiler Systems** utilize a closed heat recovering loop with multiple water source heat pumps in the more conventional manner. Typically a boiler is employed to maintain closed loop temperatures above 60°r and a cooling tower to maintain loop temperatures below 90°F. These systems are applicable in medium to large buildings regardless of whether the load is heating or cooling dominated. Due to the moderate loop temperatures, AHRI/ISO 13256-1 Water Loop Heat Pumps are required for this application.

Water Quality

In ground water situations where scaling could be heavy or where biological growth such as iron bacteria will be present, a closed loop system is recommended. The heat exchanger coils in ground water systems may, over a period of time, lose heat exchange capabilities due to a buildup of mineral deposits inside. These can be cleaned, but only by a qualified service mechanic, as special solutions and pumping equipment are required. Hot water generator coils can likewise become scaled and possibly plugged.

In areas with extremely hard water, the owner should be informed that the heat exchanger may require occasional flushing.

Units with cupronickel heat exchangers are recommended for open loop applications due to the increased resistance to build-up and corrosion, along with reduced wear caused by acid cleaning. Failure to adhere to the guidelines in the water quality table could result in loss of warranty.

Material		Copper	90/10 Cupro-Nickel	316 Stainless Steel
pH	Acidity/Alkalinity	7 - 9	7 - 9	7 - 9
Scaling	Calcium and Magnesium Carbonate	(Total Hardness) less than 350 ppm	(Total Hardness) less than 350 ppm	(Total Hardness) less than 350 ppm
Corrosion	Hydrogen Sulfide	Less than .5 ppm (rotten egg smell appears at 0.5 PPM)	10 - 50 ppm	Less than 1 ppm
	Sulfates	Less than 125 ppm	Less than 125 ppm	Less than 200 ppm
	Chlorine	Less than .5 ppm	Less than .5 ppm	Less than .5 ppm
	Chlorides	Less than 20 ppm	Less than 125 ppm	Less than 300 ppm
	Carbon Dioxide	Less than 50 ppm	10 - 50 ppm	10- 50 ppm
	Ammonia	Less than 2 ppm	Less than 2 ppm	Less than 20 ppm
	Ammonia Chloride	Less than .5 ppm	Less than .5 ppm	Less than .5 ppm
	Ammonia Nitrate	Less than .5 ppm	Less than .5 ppm	Less than .5 ppm
	Ammonia Hydroxide	Less than .5 ppm	Less than .5 ppm	Less than .5 ppm
	Ammonia Sulfate	Less than .5 ppm	Less than .5 ppm	Less than .5 ppm
	Total Dissolved Solids (TDS)	Less than 1000 ppm	1000-1500 ppm	1000-1500 ppm
	LSI Index	ˆ0.5 to ˆ.05	ˆ0.5 to ˆ.05	ˆ0.5 to ˆ.05
Iron Fouling (Biological Growth)	Iron, Fe ²⁺ (Ferrous) Bacterial Iron Potential	< .2ppm	< .2 ppm	< .2 ppm
	Iron Oxide	Less than 1 ppm. Above this level deposition will occur.	Less than 1 ppm. Above this level deposition will occur.	Less than 1 ppm. Above this level deposition will occur.
Erosion	Suspended Solids	Less than 10 ppm and filtered for max of 600 micron size	Less than 10 ppm and filtered for max of 600 micron size	Less than 10 ppm and filtered for max of 600 micron size
	Threshold Velocity (Fresh Water)	< 6 ft/sec	< 6 ft/sec	<6 ft/sec

Note:
Grains = PPM divided by 17
mg/l is equivalent to PPM

Installation Notes

Typical Unit Installation

Unit Location

Locate the unit in an indoor area that allows for easy removal of the filter and access panels. Location should have enough space for service personnel to perform maintenance or repair. Provide sufficient room to make water and electrical connection(s). Any access panel screws that would be difficult to remove after the unit is installed should be removed prior to setting the unit. **Care should be taken when units are located in unconditioned spaces to prevent damage from frozen water lines and excessive heat that could damage electrical components.**

Installing Console Units

Console units are available in left or right air return configurations. Units should be mounted level on the floor. It is not necessary to anchor the unit to the floor.

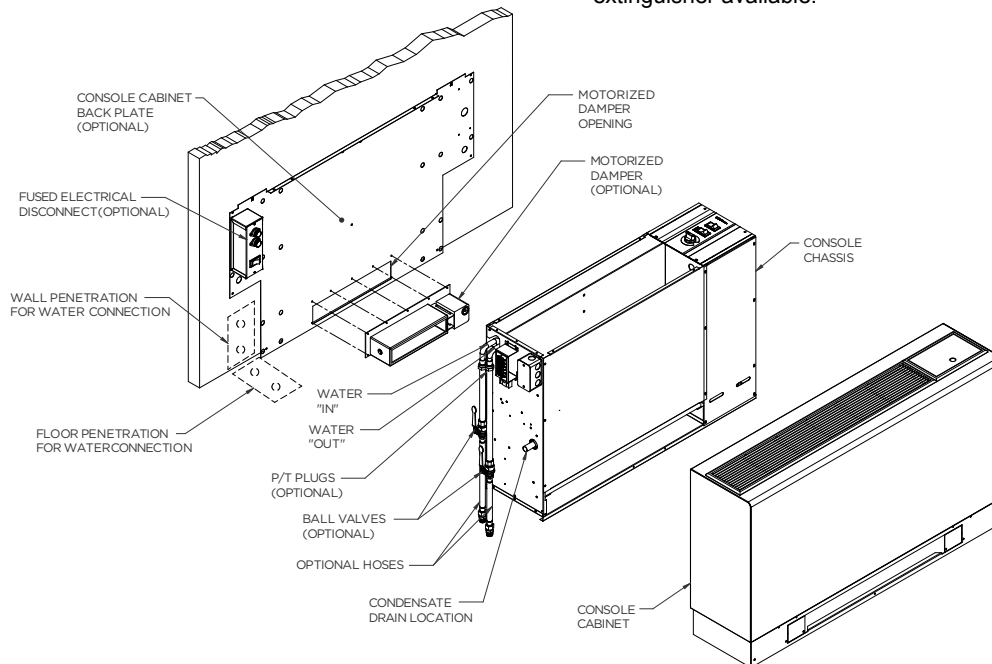

Water Piping

Piping is usually design as 'reverse return' to equalize flow paths through each unit. A short flexible pressure rated hose is used to make connection to the fixed building piping system. This hose is typically stainless steel braid and includes a swivel fitting on one end for easy removal and is flexible to help isolate the unit for quieter operation. Isolation valves for servicing, y-strainers for filtering and memory-stop flow valve or a balancing valve can be provided for consistent water flow through the unit.

All unit source water connections are fittings that accept a male pipe thread (MPT). Insert the connectors by hand, then tighten the fitting with a wrench to provide a leakproof joint. The open and closed loop piping system should include pressure/temperature

WARNING: Before performing service or maintenance operations on a system, turn off main power switches to the indoor unit. If applicable, turn off the accessory heater power switch. Electrical shock could cause personal injury.

Installing and servicing heating and air conditioning equipment can be hazardous due to system pressure and electrical components. Only trained and qualified service personnel should install, repair or service heating and air conditioning equipment. Untrained personnel can perform the basic maintenance functions of cleaning coils and cleaning and replacing filters.

All other operations should be performed by trained service personnel. When working on heating and air conditioning equipment, observe precautions in the literature, tags and labels attached to the unit and other safety precautions that may apply. Follow all safety codes. Wear safety glasses and work gloves. Use a quenching cloth for brazing operations and have a fire extinguisher available.

ports for serviceability. The proper water flow must be provided to each unit whenever the unit operates. To assure proper flow, use pressure/temperature ports to determine the flow rate. These ports should be located at the supply and return water connections on the unit. The proper flow rate cannot be accurately set without measuring the water pressure drop through the refrigerant-to-water heat exchanger. Check carefully for water leaks.

Condensate Drain

On console units, the internal condensate drain assembly consists of a drain tube which is connected to the drain pan. A condensate tube is inside all cabinets as a trapping loop; therefore, an external trap is not necessary.

Selection Example

To achieve optimal performance, proper selection of each heat pump is essential. A building load program should be used to determine the heating and cooling load of each zone. WFI Select computer software selection program can then be used to develop an accurate and complete heat pump schedule. WFI Select can be obtained from your local representative.

While WFI Select is the easiest and most accurate method to size and select equipment, however, selection can still be accomplished manually using this manual and the following selection procedure. Sizing so that the actual sensible capacity of the equipment will satisfy the sensible capacity of the zone is the recommended method for best results.

Boiler/Tower Application

Typical boiler/tower application will result in entering water temperatures of 60-90°F with 70°F for heating and 90°F for cooling. Water to refrigerant insulation option would not be required. Flow rates are 2.5 to 3 gpm per ton with 2.5 gpm per ton often representing an economical design point.

Geothermal Application

Typical geothermal application can result in a wide entering water temperature range of 30-100°F. Typically minimum heating entering water temperatures can range from 30 to 50°F depending upon loop type and geographical location. Cooling performance should be calculated using a maximum loop temperature of 100°F in most loop applications. Water flow is typically 2.5 to 3 gpm per ton with 3 gpm per ton recommended with the more extreme loop temperatures. **PLEASE NOTE THAT WATER COIL INSULATION OPTION SHOULD BE SELECTED WHEN ENTERING WATER TEMPERATURES ARE EXPECTED TO BE BELOW 45-50°F.**

Geothermal Selection Example

Step 1: Determine the actual heating and cooling loads at the desired dry bulb and wet bulb conditions.

Step 2: Obtain the following design parameters: Entering water temperature, water flow rate in GPM, air flow in CFM, water flow pressure drop and design wet and dry bulb temperatures. Air flow CFM should be between 300 and 450 CFM per ton. Unit water pressure drop should be kept as close as possible to each other to make water balancing easier. Go to the appropriate tables and find the proper indicated water flow and water temperature.

Step 3: Select a unit based on total and sensible cooling conditions. Select a unit which is closest to, but no larger than, the actual cooling load.

Step 4: Enter tables at the design water flow and water temperature. Read the total and sensible cooling capacities (Note: interpolation is permissible, extrapolation is not).

Step 5: Read the heating capacity. If it exceeds the design criteria it is acceptable. It is quite normal for water source heat pumps to

be selected on cooling capacity only since the heating output is usually greater than the cooling capacity.

Step 6: Determine the correction factors associated with the variable factors of dry bulb and wet bulb.

Corrected Total Cooling = tabulated total cooling x wet bulb correction.

Corrected Sensible Cooling = tabulated sensible cooling x wet/dry bulb correction.

Step 7: Compare the corrected capacities to the load requirements. Normally if the capacities are within 10% of the loads, the equipment is acceptable. It is better to undersize than oversize, as undersizing improves humidity control, reduces sound levels and extends the life of the equipment.

Step 8: When complete, calculate water temperature rise and assess the selection. If the units selected are not within 10% of the load calculations, then review what effect changing the GPM, water temperature and/or air flow and air temperature would have on the corrected capacities. If the desired capacity cannot be achieved, select the next larger or smaller unit and repeat the procedure. Remember, when in doubt, undersize slightly for best performance.

Example Equipment Selection - Cooling

1. Load Determination:

Assume we have determined that the appropriate cooling load at the desired dry bulb 75°F and wet bulb 60°F conditions is as follows:

Total Cooling.....	14,800 BTUH
Sensible Cooling.....	11,200 BTUH
Entering Air Temp	75°F Dry Bulb / 60°F Wet Bulb

2. Design Conditions:

Similarly, we have also obtained the following design parameters:

Entering Water Temp	100°F
Water Flow (Based upon 10°F rise in temp.)	5.5 GPM
Air Flow Required	450 CFM

3, 4 & 5. HP Selection:

After making our preliminary selection (GC18), we enter the tables at design water flow and water temperature and read

Total Cooling, Sens. Cooling and Heat of Rej. capacities:

Total Cooling.....	16,600 BTUH
Sensible Cooling.....	12,600 BTUH
Heat of Rejection.....	21,400 BTUH

6 & 7. Entering Air and Airflow Corrections:

Next, we determine our correction factors. (Refer to Correction Factor Tables - Air Flow and Entering Air correction tables — using 450 cfm. or 450÷500 nom. = 90%).

Corrected Total Cooling = 16,600 x 0.982 x 0.897 = 14,622

Corrected Sens Cooling = 12,600 x 0.933 x 0.995 = 11,697

Corrected Heat of Reject = 21,400 x 0.980 x 0.895 = 18,770

Selection Example cont.

8. Water Temperature Rise Calculation & Assessment:

NOTE: 500 = parameters for water & 485 = parameters for antifreeze solutions to 30% weight.

When we compare the Corrected Total Cooling and Corrected Sensible Cooling figures with our load requirements stated in Step 1, we discover that our selection is within +10% of our sensible load requirement. Further more, we see that our Corrected Total Cooling figure is within 1,000 Btuh of the actual indicated load.

$$HR = 500 \times GPM \times (T_{in} - T_{out})$$

$$\frac{HR}{500 \times GPM} = (T_{in} - T_{out}) \text{ or } \Delta T \text{ Rise}$$

$$\frac{18,770}{500 \times 5.5} = 6.83 \text{ } ^\circ\text{F Rise}$$

Antifreeze Corrections

Catalog performance can be corrected for antifreeze use. Please use the following table and note the example given.

Antifreeze Type	Antifreeze % by wt	Cooling Capacity	Heating Capacity	Pressure Drop
EWT - degF [DegC]		90 [32.2]	30 [-1.1]	30 [-1.1]
Water	0	1.000	1.000	1.000
Ethylene Glycol	10	0.991	0.973	1.075
	20	0.979	0.943	1.163
	30	0.965	0.917	1.225
	40	0.955	0.890	1.324
	50	0.943	0.865	1.419
Propylene Glycol	10	0.981	0.958	1.130
	20	0.969	0.913	1.270
	30	0.950	0.854	1.433
	40	0.937	0.813	1.614
	50	0.922	0.770	1.816
Ethanol	10	0.991	0.927	1.242
	20	0.972	0.887	1.343
	30	0.947	0.856	1.383
	40	0.930	0.815	1.523
	50	0.911	0.779	1.639
Methanol	10	0.986	0.957	1.127
	20	0.970	0.924	1.197
	30	0.951	0.895	1.235
	40	0.936	0.863	1.323
	50	0.920	0.833	1.399

Warning: Gray area represents antifreeze concentrations greater than 35% by weight and should be avoided due to the extreme performance penalty they represent.

Antifreeze Correction Example

Antifreeze solution is Propylene Glycol 20% by weight. Determine the corrected heating and cooling performance at 30°F and 90°F respectively as well as pressure drop at 30°F for an G Series Console GC*18.

The corrected cooling capacity at 90°F would be: 17,100 MBtuh x 0.969 = 16,569 MBtuh

The corrected heating capacity at 30°F would be: 14,300 MBtuh x 0.913 = 13,056 MBtuh

The corrected pressure drop at 30°F and 5.5 GPM would be: 18.2 feet of head x 1.270 = 23.1 feet of head

Dimensional Data - Flat Top Cabinet

GCW09-18

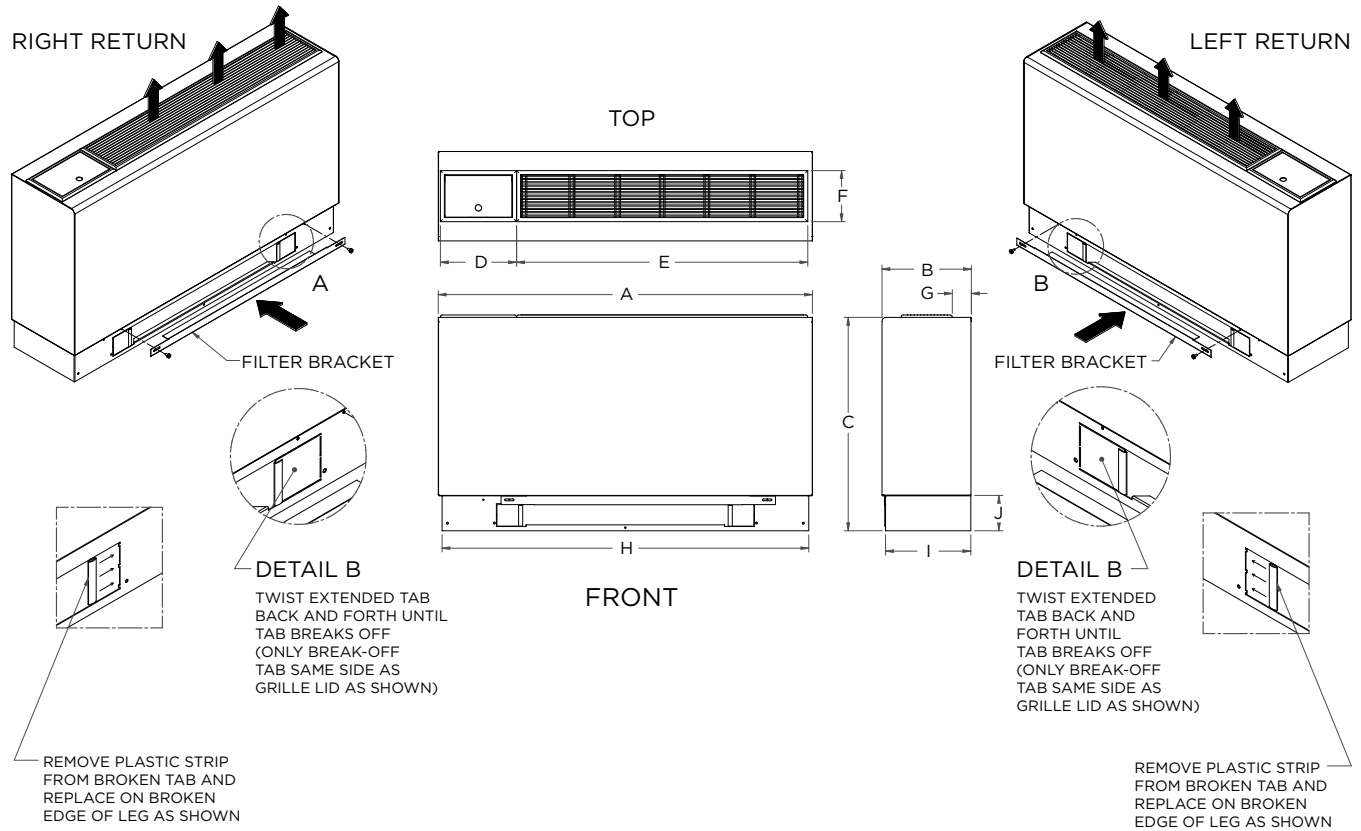

Flat Top Configuration		Overall Cabinet									
		A	B	C	D	E	F	G	H	I	J
		Width	Depth	Height	Grille Lid	Grille Length	Grille Width				
09-12	in.	45.0	10.8	25.7	9.2	35.0	6.1	2.3	44.1	10.3	4.3
	cm.	114.3	27.3	65.2	23.4	88.9	15.6	5.8	112.0	26.0	10.9
15-18	in.	50.0	12.3	25.7	9.2	35.0	6.1	3.3	49.1	11.8	4.3
	cm.	127.0	31.1	65.2	23.4	88.9	15.6	8.3	124.7	29.8	10.9

Dimensional Data - Slope Top Cabinet

GCS09-18

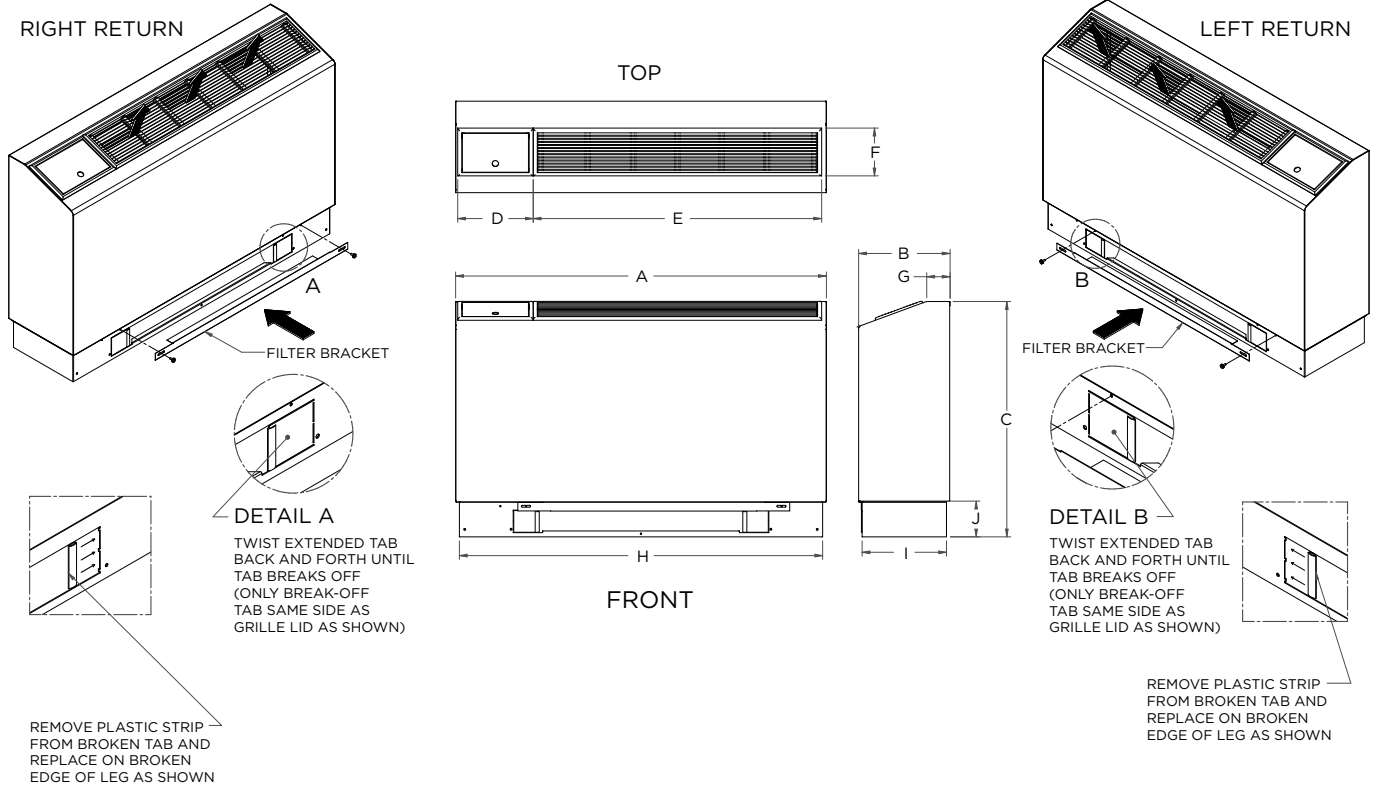

Slope Top Configuration		Overall Cabinet									
		A	B	C	D	E	F	G	H	I	J
		Width	Depth	Height	Grille Lid	Grille Length	Grille Width				
09-12	in.	45.0	11.1	28.6	9.2	35.0	6.1	2.8	44.1	10.3	4.3
	cm.	114.3	28.2	72.6	23.4	88.9	15.6	7.2	112.0	26.0	10.9
15-18	in.	50.0	12.6	29.1	9.2	35.0	6.1	2.5	49.1	11.8	4.3
	cm.	127.0	32.0	73.9	23.4	88.9	15.6	6.4	124.7	29.8	10.9

Dimensional Data - Extended Slope Top Cabinet

GCE09-18

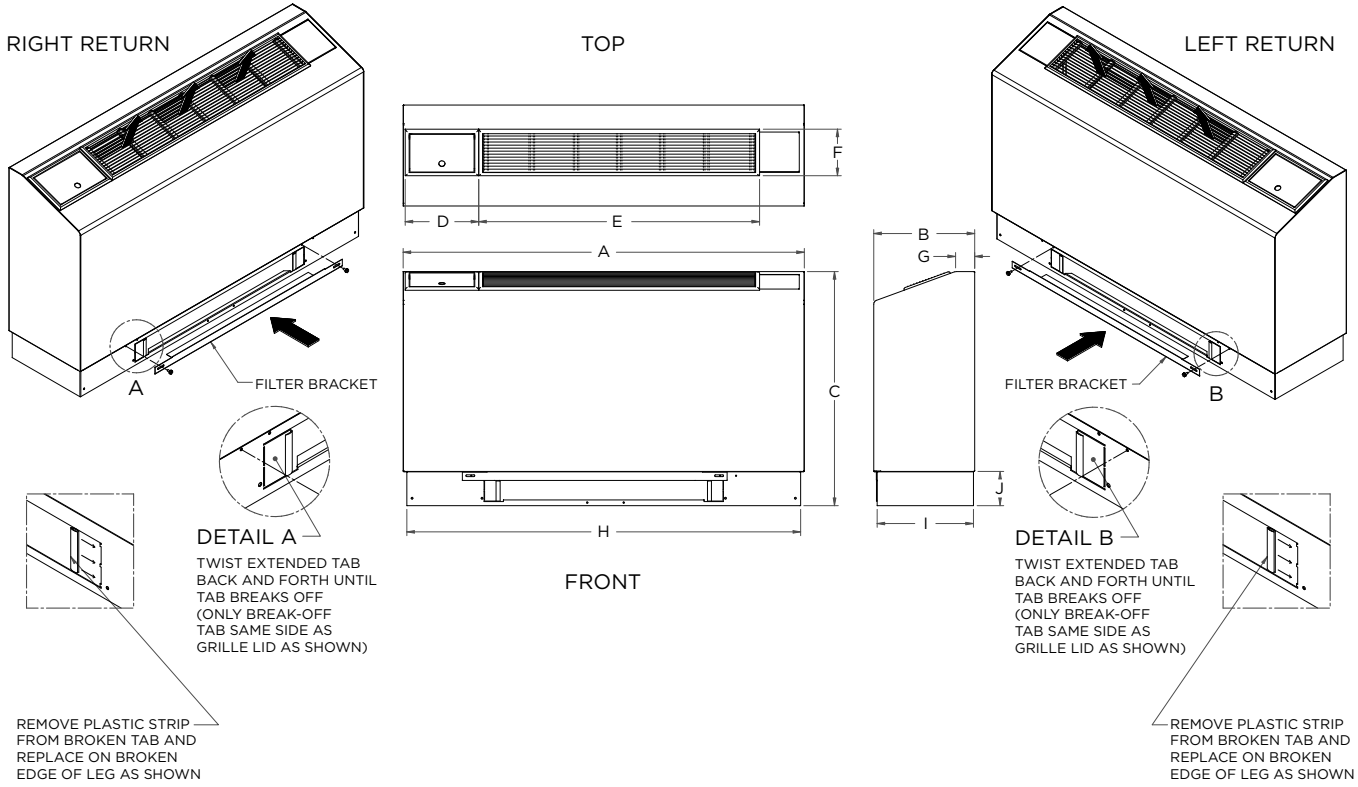

Ext. Slope Top Configuration		Overall Cabinet									
		A	B	C	D	E	F	G	H	I	J
		Width	Depth	Height	Grille Lid	Grille Length	Grille Width				
09-12	in.	50.0	12.6	29.1	9.2	35.0	6.1	2.4	49.1	12.0	4.3
	cm.	127.0	32.0	73.9	23.4	88.9	15.6	6.1	124.7	30.5	10.9
15-18	in.	55.0	12.6	29.1	9.2	35.0	6.1	2.5	54.1	11.8	4.3
	cm.	139.7	32.0	73.9	23.4	88.9	15.6	6.4	137.4	29.8	10.9

Dimensional Data - Right Return Controls Detail

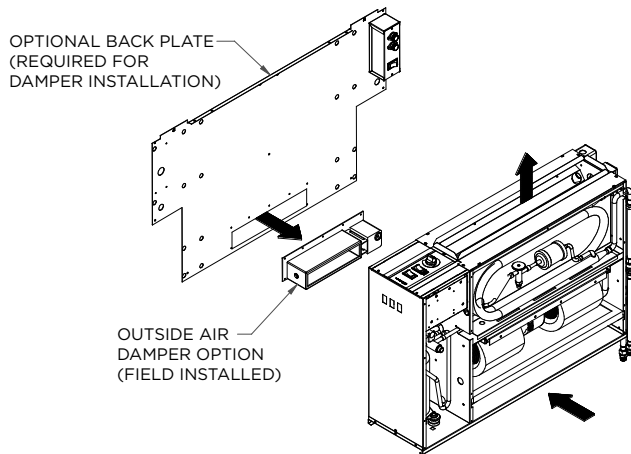
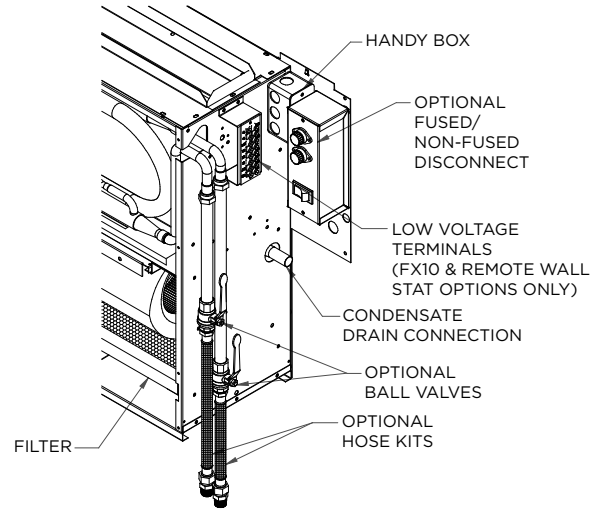
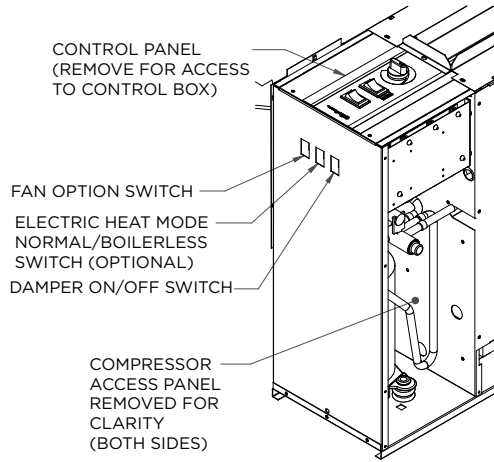

Dimensional Data - Right Return Chassis

Data = inches (cm)

Models 09-12

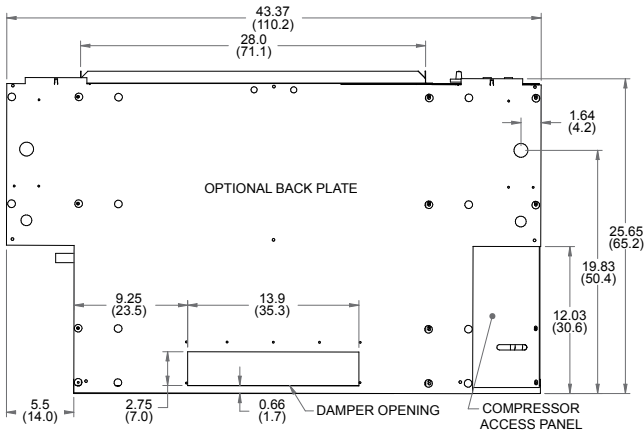
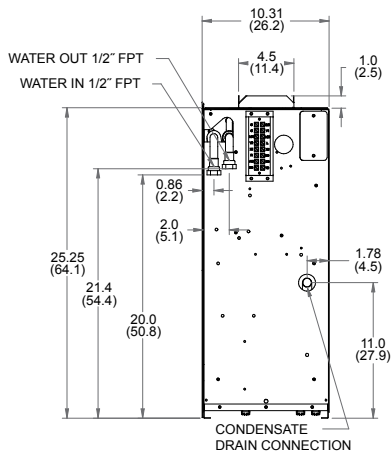
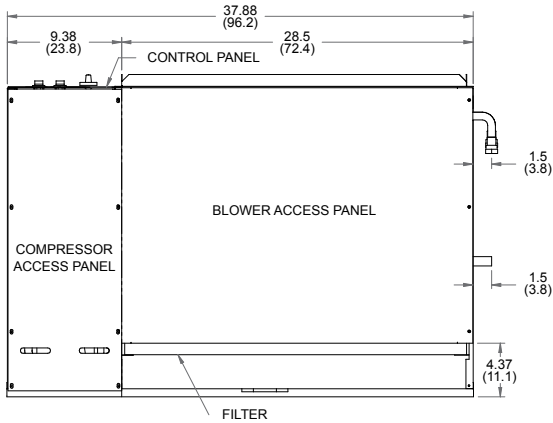

Models 15-18

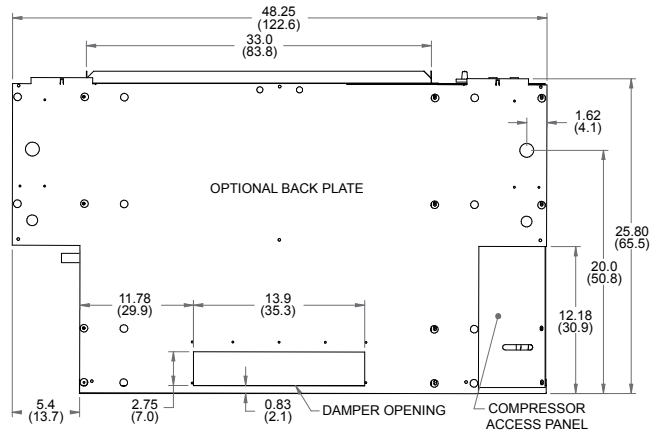
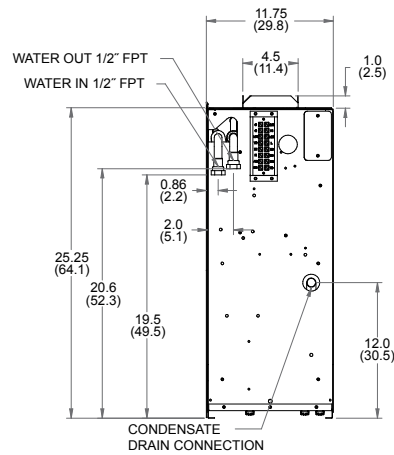
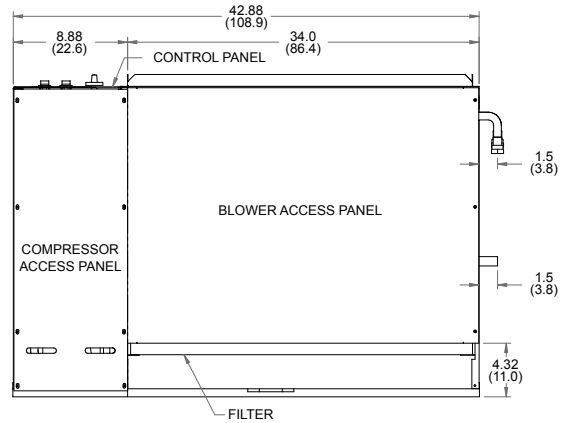

Dimensional Data - Left Return Controls Detail

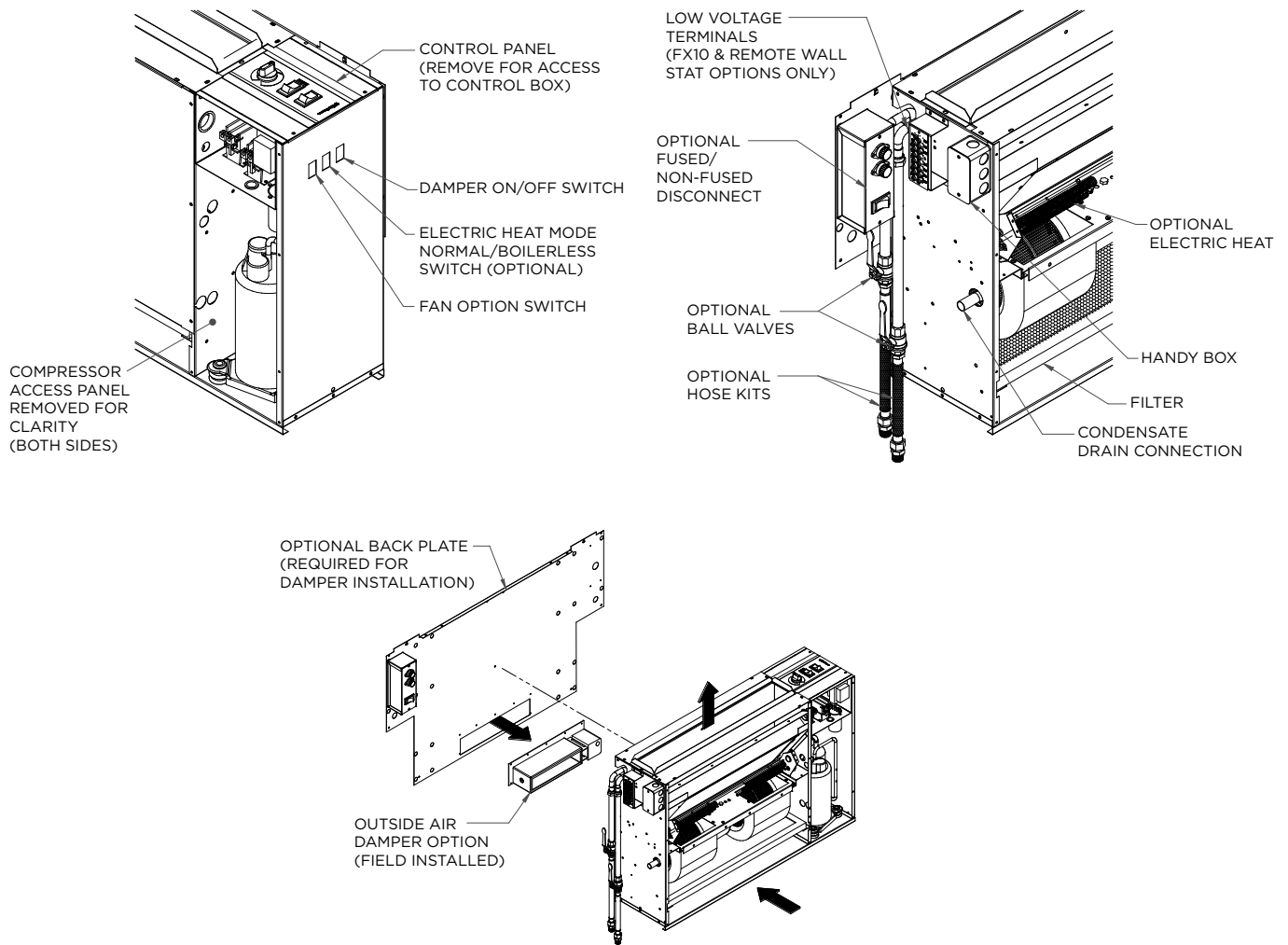

Dimensional Data - Left Return Chassis

Data = inches (cm)

Models 09-12

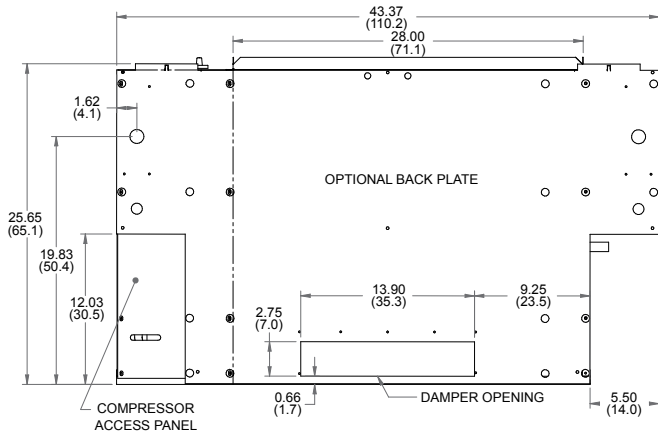
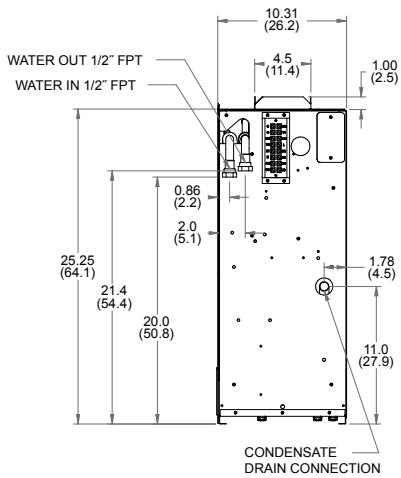
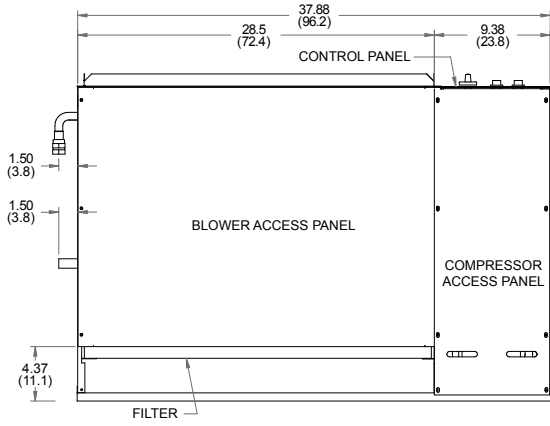

Models 15-18

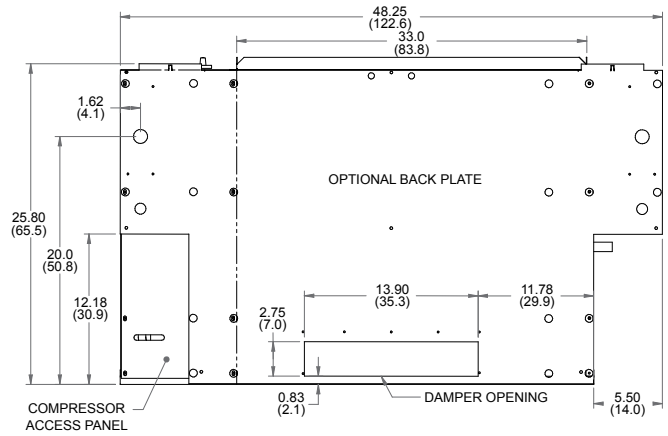
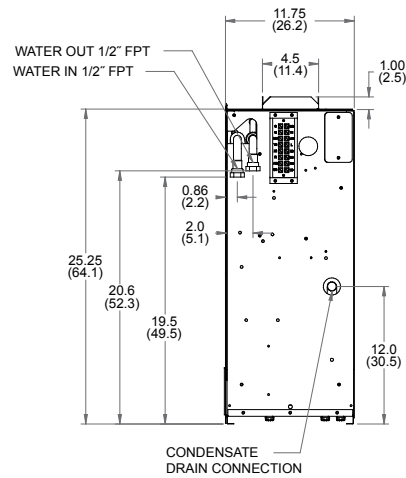
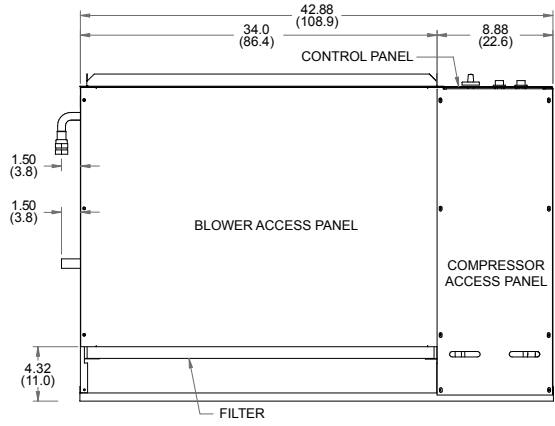

Physical Data

Model	Consoles			
	09	12	15	18
Compressor (1 each)	LG Rotary			
Factory Charge R410A, oz [kg]	25 [0.71]	29 [0.82]	38 [1.08]	34 [0.96]
Blower Motor & Blower	PSC 2 Speeds			
Blower Motor Type/Speeds	PSC 2 Speeds			
Blower Motor- hp [W]	1/20 [37]	1/20 [37]	1/12 [62]	1/12 [62]
Blower Wheel Size (Dia x W), in. [mm]	5.75 x 5.5 [146 x 140]	5.75 x 5.5 [146 x 140]	6.0 x 6.5 [152 x 165]	6.0 x 6.5 [152 x 165]
Coax and Water Piping				
Water Connections Size - FPT - in [mm]	1/2" [12.7]	1/2" [12.7]	1/2" [12.7]	1/2" [12.7]
Coax & Piping Water Volume - gal [l]	0.15 [0.6]	0.18 [0.7]	0.35 [1.3]	0.35 [1.3]
Consoles				
Air Coil Dimensions (H x W), in. [mm]	8 x 22 [203 x 559]	8 x 22 [203 x 559]	8 x 30 [203 x 762]	8 x 30 [203 x 762]
Air Coil Total Face Area, ft2 [m2]	1.2 [0.114]	1.2 [0.114]	1.7 [0.155]	1.7 [0.155]
Air Coil Tube Size, in [mm]	3/8 [9.5]	3/8 [9.5]	3/8 [9.5]	3/8 [9.5]
Air Coil Number of rows	3	3	4	4
Filter Standard - 1" [25.4mm] Throwaway	1 - 10 x 28 [254 x 711]	1 - 10 x 28 [254 x 711]	1 - 12 x 33 [305 x 838]	1 - 12 x 33 [305 x 838]
Weight - Operating, lb [kg]	210 [91]	210 [95]	230 [102]	235 [107]
Weight - Packaged, lb [kg]	220 [100]	220 [100]	240 [109]	245 [111]

3/4/08

Electrical Data

Model	Rated Voltage	Voltage Min/Max	Compressor			Blower Motor FLA	Total Unit FLA	Min Circ Amp	Max Fuse/HACR
			MCC	RLA	LRA				
09	208-230/60/1	197/253	6.4	4.1	21.0	0.50	4.6	5.6	10
	265/60/1*	238/292	na	4.3	22.0	0.50	4.8	5.9	10
12	208-230/60/1	197/253	7.7	4.9	25.0	0.50	5.4	6.7	10
	265/60/1*	238/292	na	5.3	22.0	0.50	5.8	7.1	10
15	208-230/60/1	197/253	9.2	5.9	29.0	0.69	6.6	8.1	10
	265/60/1*	238/292	na	5.6	28.0	0.65	6.3	7.7	10
18	208-230/60/1	197/253	10.4	6.7	33.5	0.69	7.3	9.0	15
	265/60/1*	238/292	na	7.3	28.0	0.65	8.0	9.8	15

HACR circuit breaker in USA only

* RLA determine per UL1995 test procedure and not from compressor rating.

4/8/08

Auxiliary Heat Ratings

Model	Rated Voltage	Voltage Min./Max.	Heater Element Watts	Blower Motor FLA	Heater Element FLA	Total Unit FLA	Min. Circuit Amp.	Max. Fuse/Brkr.
09-12	208/60/1	197/254	2000	0.50	9.62	10.1	12.7	15
	230/60/1	197/254	2445	0.50	10.63	11.1	13.9	15
	265/60/1	239/292	2000	0.55	7.55	8.1	10.1	15
15-18	208/60/1	197/254	3000	0.69	14.42	15.1	18.9	20
	230/60/1	197/254	3668	0.69	15.95	16.6	20.8	25
	265/60/1	239/292	3000	0.65	11.32	12.0	15.0	15

Always refer to unit name plate data prior to installation.

3/4/08

Blower Performance Data Pressure Drop

Model	CFM	
	Low Speed	High Speed
09	300	350
12	300	350
15	450	500
18	450	500

Factory settings are in **Bold**
Air flow values are with dry coil and standard filter.

For wet coil performance first calculate the face velocity of the air coil (Face Velocity [fpm] = Airflow [cfm] / Face Area [sq ft]). Then for velocities of 200 fpm reduce the static capability by 0.03 in. wg, 300 fpm by 0.08 in. wg, 400 fpm by 0.12in. wg. and 500 fpm by 0.16 in. wg.

Model	GPM	Pressure Drop (psi)				
		30°F	50°F	70°F	90°F	110°F
09	1.2	1.0	0.9	0.8	0.7	0.6
	1.8	2.3	2.2	2.0	1.9	1.8
	2.5	3.8	3.7	3.5	3.3	3.1
12	1.5	0.9	0.8	0.7	0.6	0.5
	2.3	1.7	1.5	1.4	1.3	1.1
	3.5	3.0	2.7	2.5	2.4	2.2
15	2.0	1.7	1.6	1.5	1.4	1.3
	3.0	3.3	3.2	3.0	2.9	2.8
	4.5	5.7	5.5	5.3	5.1	4.9
18	3.0	1.7	1.6	1.5	1.4	1.3
	4.0	4.1	4.0	3.9	3.7	3.6
	5.5	7.9	7.6	7.4	7.2	6.9

12/14/09

Correction Factor Tables

Cooling Capacity Corrections

Entering Air WB °F	Total Clg Cap	Sensible Cooling Capacity Multipliers - Entering DB °F										Power Input	Heat of Rejection
		60	65	70	75	80	80.6	85	90	95	100		
45	0.719	0.891	1.058	1.128	*	*	*	*	*	*	*	0.898	0.741
50	0.719	0.893	0.980	1.106	*	*	*	*	*	*	*	0.898	0.741
55	0.812	0.629	0.844	1.026	1.172	*	*	*	*	*	*	0.922	0.819
60	0.897			0.820	0.995	1.206	1.238	*	*	*	*	0.955	0.895
65	0.960			0.568	0.810	1.004	1.052	1.227	*	*	*	0.982	0.951
66.2	0.984			0.505	0.743	1.002	1.027	1.151	*	*	*	0.993	0.980
67	1.000			0.463	0.699	1.000	1.011	1.101	1.310	*	*	1.000	1.000
70	1.047				0.599	0.865	0.879	1.007	1.225	1.433	*	1.018	1.029
75	1.148					0.567	0.584	0.734	0.956	1.261	1.476	1.056	1.118

Note: * Sensible capacity equals total capacity at conditions shown.

7/20/06

Heating Capacity Corrections

Ent Air DB °F	Heating Corrections		
	Htg Cap	Power	Heat of Ext
45	1.050	0.749	1.158
50	1.059	0.859	1.130
55	1.043	0.894	1.096
60	1.033	0.947	1.064
65	1.023	0.974	1.030
68	1.009	0.990	1.012
70	1.000	1.000	1.000
75	1.011	1.123	0.970
80	1.000	1.196	0.930

7/20/06

Reference Calculations

Heating Calculations:	Cooling Calculations:
$LWT = EWT - \frac{HE}{GPM \times 500}$	$LWT = EWT + \frac{HR}{GPM \times 500}$
$LAT = EAT + \frac{HC}{CFM \times 1.08}$	$LAT (DB) = EAT (DB) - \frac{SC}{CFM \times 1.08}$
$TH = HC + HW$	$LC = TC - SC$
	$S/T = \frac{SC}{TC}$

Legend and Notes

ABBREVIATIONS AND DEFINITIONS:

CFM = airflow, cubic feet/minute
 EWT = entering water temperature, Fahrenheit
 GPM = water flow in gallons/minute
 WPD = water pressure drop, PSI and feet of water
 EAT = entering air temperature, Fahrenheit (dry bulb/wet bulb)
 HC = air heating capacity, MBTUH
 TC = total cooling capacity, MBTUH
 SC = sensible cooling capacity, MBTUH
 KW = total power unit input, kilowatts
 HR = total heat of rejection, MBTUH

HE = total heat of extraction, MBTUH
 HW = desuperheater capacity, MBTUH
 EER = Energy Efficient Ratio = BTU output/Watt input
 COP = Coefficient of Performance = BTU output/BTU input
 LWT = leaving water temperature, °F
 LAT = leaving air temperature, °F
 TH = total heating capacity, MBTUH
 LC = latent cooling capacity, MBTUH
 S/T = sensible to total cooling ratio

Notes to Performance Data Tables

- Performance ratings are based on 80°F DB / 67°F WB EAT for cooling and 70°F DB EAT for heating.
- Three flow rates are shown for each unit. The lowest flow rate shown is used for geothermal open loop/well water systems with a minimum of 50°F EWT. The middle flow rate shown is the minimum geothermal closed loop flow rate. The highest flow rate shown is optimum for geothermal closed loop systems and the suggested flow rate for boiler/ tower applications.
- The desuperheater numbers are based on a flow rate of 0.4 GPM/ton of rated capacity with an EWT of 90°F.
- Entering water temperatures below 40°F assumes 15% antifreeze solution.
- For non-standard EAT conditions, apply the appropriate correction factors on (Refer to Correction Factor Tables).
- Interpolation between EWT, GPM and CFM data is permissible.

Operating Limits

Operating Limits	Cooling		Heating	
	(°F)	(°C)	(°F)	(°C)
Air Limits				
Min. Ambient Air	45	7.2	45	7.2
Rated Ambient Air	80	26.7	70	21.1
Max. Ambient Air	100	37.8	85	29.4
Min. Entering Air	50	10.0	40	4.4
Rated Entering Air db/wb	80.6/66.2	27/19	68	20.0
Max. Entering Air db/wb	110/83	43/28.3	80	26.7
Water Limits				
Min. Entering Water	30	-1.1	20	-6.7
Normal Entering Water	50-110	10-43.3	30-70	-1.1
Max. Entering Water	120	48.9	90	32.2

NOTE: Minimum/maximum limits are only for start-up conditions, and are meant for bringing the space up to occupancy temperature. Units are not designed to operate at the minimum/maximum conditions on a regular basis. The operating limits are dependent upon three primary factors: 1) water temperature, 2) return air temperature, and 3) ambient temperature. When any of the factors are at the minimum or maximum levels, the other two factors must be at the normal level for proper and reliable unit operation.

GC09 - Performance Data

300 Rated CFM Heating / Cooling

Performance capacities shown in thousands of Btu/h.

EWT °F	Flow Rate GPM	Water Pressure Drop		HEATING - EAT 70 °F					COOLING - EAT 80/67 °F					
		PSI	FT/HD	HC kBtu/h	Power kW	HE kBtu/h	LAT °F	COP	TC kBtu/h	SC kBtu/h	S/T Ratio	Power kW	HR kBtu/h	EER
20	1.2	1.1	2.5	Operation not recommended					Operation not recommended					
	1.8	2.4	5.6	Operation not recommended					Operation not recommended					
	2.5	3.8	8.8	6.8	0.60	4.8	89.0	3.35	Operation not recommended					
30	1.2	1.0	2.3	Operation not recommended					Operation not recommended					
	1.8	2.3	5.4	6.9	0.60	4.8	89.3	3.38	12.1	7.3	0.61	0.38	13.4	31.8
	2.5	3.8	8.8	7.3	0.63	5.1	90.5	3.40	12.2	7.4	0.61	0.36	13.4	33.9
40	1.2	1.0	2.2	7.6	0.62	5.5	91.5	3.63	Operation not recommended					
	1.8	2.3	5.2	7.9	0.62	5.8	92.4	3.72	11.5	7.1	0.62	0.41	12.9	28.1
	2.5	3.8	8.7	8.3	0.64	6.1	93.7	3.80	11.6	7.2	0.62	0.39	12.9	30.0
50	1.2	0.9	2.1	8.8	0.65	6.6	95.2	4.00	10.7	6.8	0.63	0.45	12.3	23.6
	1.8	2.2	5.1	9.1	0.65	6.9	96.0	4.08	10.9	6.9	0.63	0.44	12.3	24.9
	2.5	3.7	8.5	9.4	0.66	7.1	97.0	4.17	11.0	7.0	0.64	0.41	12.4	26.6
60	1.2	0.9	2.0	10.3	0.68	8.0	99.8	4.46	10.4	6.7	0.64	0.52	12.1	19.9
	1.8	2.1	4.9	10.5	0.68	8.2	100.5	4.53	10.5	6.7	0.64	0.50	12.2	21.0
	2.5	3.6	8.3	10.8	0.69	8.5	101.3	4.60	10.7	6.9	0.64	0.47	12.3	22.4
70	1.2	0.8	1.8	11.8	0.71	9.4	104.5	4.88	10.0	6.5	0.65	0.59	12.0	17.1
	1.8	2.0	4.7	12.0	0.71	9.6	105.0	4.93	10.1	6.6	0.65	0.56	12.1	18.0
	2.5	3.5	8.1	12.2	0.72	9.8	105.7	4.99	10.3	6.7	0.65	0.54	12.1	19.2
80	1.2	0.8	1.7	12.7	0.73	10.2	107.3	5.11	9.5	6.3	0.67	0.65	11.7	14.5
	1.8	2.0	4.6	12.9	0.74	10.4	107.9	5.12	9.6	6.5	0.67	0.62	11.7	15.5
	2.5	3.4	7.9	13.1	0.75	10.5	108.4	5.13	9.9	6.5	0.66	0.60	11.9	16.4
90	1.2	0.7	1.6	13.6	0.76	11.0	110.0	5.24	9.2	6.1	0.67	0.72	11.6	12.7
	1.8	1.9	4.4	13.8	0.77	11.2	110.6	5.25	9.3	6.2	0.67	0.69	11.7	13.5
	2.5	3.3	7.6	14.0	0.78	11.3	111.2	5.26	9.4	6.3	0.67	0.67	11.7	14.1
100	1.2	0.7	1.5	Operation not recommended					Operation not recommended					
	1.8	1.8	4.3						9.0	6.0	0.67	0.76	11.6	11.8
	2.5	3.2	7.4						9.1	6.1	0.67	0.74	11.6	12.3
110	1.2	0.6	1.5						Operation not recommended					
	1.8	1.8	4.1						8.6	5.8	0.67	0.83	11.5	10.4
	2.5	3.1	7.2						8.7	5.9	0.68	0.81	11.5	10.7
120	1.2	0.6	1.4						Operation not recommended					
	1.8	1.7	4.0						8.2	5.5	0.67	0.90	11.3	9.1
	2.5	3.0	6.9						8.3	5.6	0.68	0.88	11.3	9.5

GC12 - Performance Data

350 Rated CFM Heating / Cooling

Performance capacities shown in thousands of Btuh.

EWT °F	Flow Rate GPM	Water Pressure Drop		HEATING - EAT 70 °F					COOLING - EAT 80/67 °F											
		PSI	FT/HD	HC kBtuh	Power kW	HE kBtuh	LAT °F	COP	TC kBtuh	SC kBtuh	S/T Ratio	Power kW	HR kBtuh	EER						
20	1.5	1.0	2.3	Operation not recommended					Operation not recommended											
	2.3	1.7	4.0	Operation not recommended					Operation not recommended											
	3.5	3.2	7.4	8.6	0.80	5.9	90.8	3.15	Operation not recommended											
30	1.5	0.9	2.1	Operation not recommended					Operation not recommended											
	2.3	1.7	3.8	10.0	0.85	7.1	94.3	3.44	14.2	9.8	0.69	0.45	15.8	31.6						
	3.5	3.0	6.9	10.2	0.86	7.3	95.1	3.48	14.4	10.0	0.69	0.42	15.9	34.1						
40	1.5	0.9	2.0	10.8	0.88	7.8	96.7	3.62	Operation not recommended											
	2.3	1.6	3.7	11.0	0.88	8.0	97.0	3.66	13.7	9.5	0.70	0.54	15.5	25.5						
	3.5	2.9	6.6	11.3	0.89	8.2	97.8	3.72	13.9	9.7	0.70	0.50	15.6	27.6						
50	1.5	0.8	1.8	11.9	0.91	8.8	99.6	3.86	13.0	9.1	0.70	0.64	15.2	20.2						
	2.3	1.5	3.5	12.1	0.91	9.0	100.0	3.89	13.1	9.2	0.71	0.62	15.2	21.1						
	3.5	2.7	6.2	12.3	0.92	9.2	100.6	3.94	13.3	9.4	0.71	0.58	15.3	22.8						
60	1.5	0.8	1.7	13.2	0.94	10.0	103.0	4.14	12.1	8.6	0.71	0.71	14.5	17.0						
	2.3	1.4	3.3	13.4	0.94	10.2	103.4	4.16	12.2	8.7	0.71	0.68	14.5	17.8						
	3.5	2.6	6.0	13.7	0.96	10.4	104.2	4.19	12.4	8.9	0.71	0.65	14.6	19.2						
70	1.5	0.7	1.6	14.5	0.97	11.2	106.4	4.39	11.1	8.0	0.72	0.77	13.8	14.4						
	2.3	1.4	3.2	14.7	0.98	11.4	106.9	4.40	11.3	8.1	0.72	0.75	13.8	15.0						
	3.5	2.5	5.8	15.0	1.00	11.6	107.7	4.41	11.5	8.3	0.72	0.71	13.9	16.3						
80	1.5	0.7	1.5	15.6	1.03	12.1	109.4	4.45	10.6	7.8	0.73	0.84	13.5	12.6						
	2.3	1.3	3.0	15.9	1.04	12.3	110.0	4.48	10.9	7.9	0.73	0.80	13.6	13.5						
	3.5	2.5	5.7	16.1	1.05	12.5	110.6	4.50	11.0	8.0	0.73	0.78	13.7	14.1						
90	1.5	0.6	1.4	16.7	1.07	13.0	112.1	4.55	10.2	7.5	0.73	0.92	13.4	11.1						
	2.3	1.3	2.9	16.9	1.09	13.2	112.8	4.56	10.4	7.6	0.74	0.88	13.4	11.8						
	3.5	2.4	5.5	17.2	1.10	13.4	113.5	4.57	10.5	7.7	0.73	0.85	13.4	12.4						
100	1.5	0.6	1.3	Operation not recommended					Operation not recommended											
	2.3	1.2	2.8						9.7	7.3	0.75	1.00	13.1	9.7						
	3.5	2.3	5.3						9.8	7.4	0.75	0.97	13.1	10.1						
110	1.5	0.5	1.2						Operation not recommended						Operation not recommended					
	2.3	1.1	2.6						8.9	6.9	0.77	1.11	12.7	8.1						
	3.5	2.2	5.1						9.1	7.0	0.77	1.08	12.8	8.4						
120	1.5	0.5	1.2						Operation not recommended						Operation not recommended					
	2.3	1.1	2.5						8.5	6.7	0.79	1.21	12.6	7.0						
	3.5	2.1	4.9						8.7	6.8	0.78	1.18	12.7	7.4						

GC15 - Performance Data

450 Rated CFM Heating / Cooling

Performance capacities shown in thousands of Btuh.

EWT °F	Flow Rate GPM	Water Pressure Drop		HEATING - EAT 70 °F					COOLING - EAT 80/67 °F					
		PSI	FT/HD	HC kBtuh	Power kW	HE kBtuh	LAT °F	COP	TC kBtuh	SC kBtuh	S/T Ratio	Power kW	HR kBtuh	EER
20	2.0	1.8	4.1	Operation not recommended					Operation not recommended					
	3.0	3.4	7.8	Operation not recommended					Operation not recommended					
	4.5	5.9	13.6	10.7	0.93	7.5	90.0	3.37	Operation not recommended					
30	2.0	1.7	3.9	Operation not recommended					Operation not recommended					
	3.0	3.3	7.6	11.8	0.95	8.5	92.2	3.62	17.1	12.2	0.71	0.48	18.7	35.6
	4.5	5.7	13.2	12.3	0.97	9.0	93.3	3.72	17.3	12.4	0.71	0.45	18.9	38.4
40	2.0	1.7	3.8	12.7	0.95	9.4	94.1	3.93	Operation not recommended					
	3.0	3.2	7.5	12.9	0.96	9.6	94.6	3.94	16.7	12.0	0.72	0.60	18.8	27.8
	4.5	5.6	12.9	13.4	0.98	10.1	95.6	4.02	17.0	12.2	0.72	0.57	18.9	30.0
50	2.0	1.6	3.7	13.9	0.95	10.6	96.5	4.27	16.2	11.7	0.72	0.75	18.8	21.5
	3.0	3.2	7.3	14.1	0.97	10.8	97.1	4.28	16.4	11.8	0.72	0.72	18.8	22.6
	4.5	5.5	12.7	14.6	0.99	11.2	97.9	4.31	16.6	12.0	0.72	0.68	18.9	24.4
60	2.0	1.6	3.6	15.2	0.96	12.0	99.4	4.66	15.5	11.4	0.74	0.84	18.3	18.3
	3.0	3.1	7.1	15.6	0.97	12.2	100.0	4.69	15.6	11.5	0.74	0.81	18.4	19.2
	4.5	5.4	12.5	16.1	1.00	12.7	101.0	4.72	15.9	11.8	0.74	0.77	18.5	20.7
70	2.0	1.5	3.5	16.6	0.96	13.3	102.2	5.05	14.7	11.1	0.76	0.94	17.9	15.7
	3.0	3.0	7.0	17.0	0.98	13.7	103.0	5.08	14.9	11.3	0.76	0.90	18.0	16.5
	4.5	5.3	12.2	17.6	1.00	14.1	104.1	5.12	15.2	11.5	0.76	0.86	18.1	17.8
80	2.0	1.5	3.4	18.3	1.03	14.8	105.7	5.22	14.2	10.9	0.77	1.00	17.6	14.1
	3.0	3.0	6.8	18.6	1.04	15.1	106.3	5.24	14.5	11.1	0.77	0.96	17.7	15.1
	4.5	5.2	12.0	18.9	1.05	15.3	106.8	5.26	14.7	11.2	0.76	0.93	17.8	15.8
90	2.0	1.4	3.2	19.6	1.07	15.9	108.3	5.35	13.7	10.6	0.77	1.08	17.4	12.7
	3.0	2.9	6.7	19.9	1.09	16.2	108.9	5.36	13.9	10.8	0.78	1.03	17.4	13.5
	4.5	5.1	11.8	20.2	1.10	16.4	109.5	5.38	14.1	10.9	0.77	1.00	17.5	14.1
100	2.0	1.4	3.1	Operation not recommended					Operation not recommended					
	3.0	2.8	6.5						13.4	10.5	0.78	1.14	17.3	11.8
	4.5	5.0	11.6						13.6	10.6	0.78	1.10	17.3	12.3
110	2.0	1.3	3.0						Operation not recommended					
	3.0	2.8	6.4						12.8	10.1	0.79	1.23	17.0	10.4
	4.5	4.9	11.3						13.0	10.3	0.79	1.20	17.1	10.8
120	2.0	1.3	2.9						Operation not recommended					
	3.0	2.7	6.2						11.3	9.2	0.81	1.39	16.0	8.1
	4.5	4.8	11.1						11.5	9.3	0.81	1.35	16.1	8.5

GC18 - Performance Data

500 Rated CFM Heating / Cooling

Performance capacities shown in thousands of Btuh.

EWT °F	Flow Rate GPM	Water Pressure Drop		HEATING - EAT 70 °F					COOLING - EAT 80/67 °F					
		PSI	FT/HD	HC kBtuh	Power kW	HE kBtuh	LAT °F	COP	TC kBtuh	SC kBtuh	S/T Ratio	Power kW	HR kBtuh	EER
20	3.0	1.8	4.1	Operation not recommended					Operation not recommended					
	4.0	4.2	9.7	Operation not recommended					Operation not recommended					
	5.5	8.0	18.5	13.0	1.20	8.9	92.0	3.16	Operation not recommended					
30	3.0	1.7	3.9	Operation not recommended					Operation not recommended					
	4.0	4.1	9.6	14.2	1.24	10.0	94.3	3.35	22.2	16.0	0.72	0.69	24.6	32.1
	5.5	7.9	18.2	14.3	1.25	10.1	94.5	3.36	22.5	16.3	0.72	0.65	24.7	34.6
40	3.0	1.7	3.8	15.5	1.26	11.2	96.7	3.60	Operation not recommended					
	4.0	4.1	9.4	15.8	1.27	11.5	97.3	3.65	21.3	15.5	0.72	0.79	24.1	26.9
	5.5	7.8	17.9	16.2	1.28	11.8	98.0	3.71	21.7	15.8	0.73	0.75	24.2	29.1
50	3.0	1.6	3.7	17.2	1.28	12.8	99.9	3.93	20.3	14.8	0.73	0.93	23.5	21.9
	4.0	4.0	9.2	17.6	1.29	13.2	100.5	3.98	20.5	14.9	0.73	0.89	23.5	23.0
	5.5	7.6	17.6	18.1	1.31	13.6	101.5	4.05	20.8	15.2	0.73	0.84	23.7	24.8
60	3.0	1.6	3.6	19.2	1.30	14.8	103.6	4.33	19.0	13.9	0.73	1.01	22.4	18.7
	4.0	3.9	9.1	19.7	1.32	15.2	104.4	4.37	19.2	14.1	0.73	0.97	22.5	19.7
	5.5	7.5	17.3	20.3	1.34	15.7	105.6	4.43	19.5	14.4	0.74	0.92	22.6	21.2
70	3.0	1.5	3.5	21.3	1.32	16.8	107.4	4.71	17.6	13.1	0.74	1.09	21.3	16.1
	4.0	3.9	8.9	21.8	1.34	17.2	108.3	4.75	17.8	13.2	0.74	1.06	21.5	16.9
	5.5	7.4	17.1	22.5	1.37	17.8	109.7	4.80	18.2	13.5	0.74	1.00	21.6	18.2
80	3.0	1.5	3.4	23.3	1.40	18.6	111.2	4.88	17.1	12.9	0.75	1.25	21.3	13.7
	4.0	3.8	8.8	23.7	1.41	18.9	111.9	4.92	17.4	13.1	0.75	1.19	21.5	14.7
	5.5	7.3	16.9	24.0	1.43	19.1	112.4	4.93	17.7	13.2	0.75	1.15	21.6	15.3
90	3.0	1.4	3.2	24.7	1.44	19.8	113.8	5.03	16.6	12.6	0.76	1.41	21.4	11.8
	4.0	3.7	8.6	25.1	1.46	20.1	114.5	5.04	16.9	12.8	0.76	1.34	21.5	12.6
	5.5	7.2	16.6	25.5	1.48	20.5	115.2	5.06	17.1	12.9	0.75	1.30	21.5	13.2
100	3.0	1.4	3.1	Operation not recommended					Operation not recommended					
	4.0	3.7	8.5						Operation not recommended					
	5.5	7.1	16.3						16.4	12.5	0.76	1.49	21.5	11.0
110	3.0	1.3	3.0						Operation not recommended					
	4.0	3.6	8.3						Operation not recommended					
	5.5	6.9	15.9						16.6	12.6	0.76	1.44	21.5	11.5
120	3.0	1.3	2.9	Operation not recommended										
	4.0	3.5	8.2	Operation not recommended										
	5.5	6.8	15.7	15.0	11.7	0.80	1.77	20.8	8.3					

Wiring Schematics cont.

CCM w/EH - ELECTRONIC THERMOSTAT

208-230-265/60/1

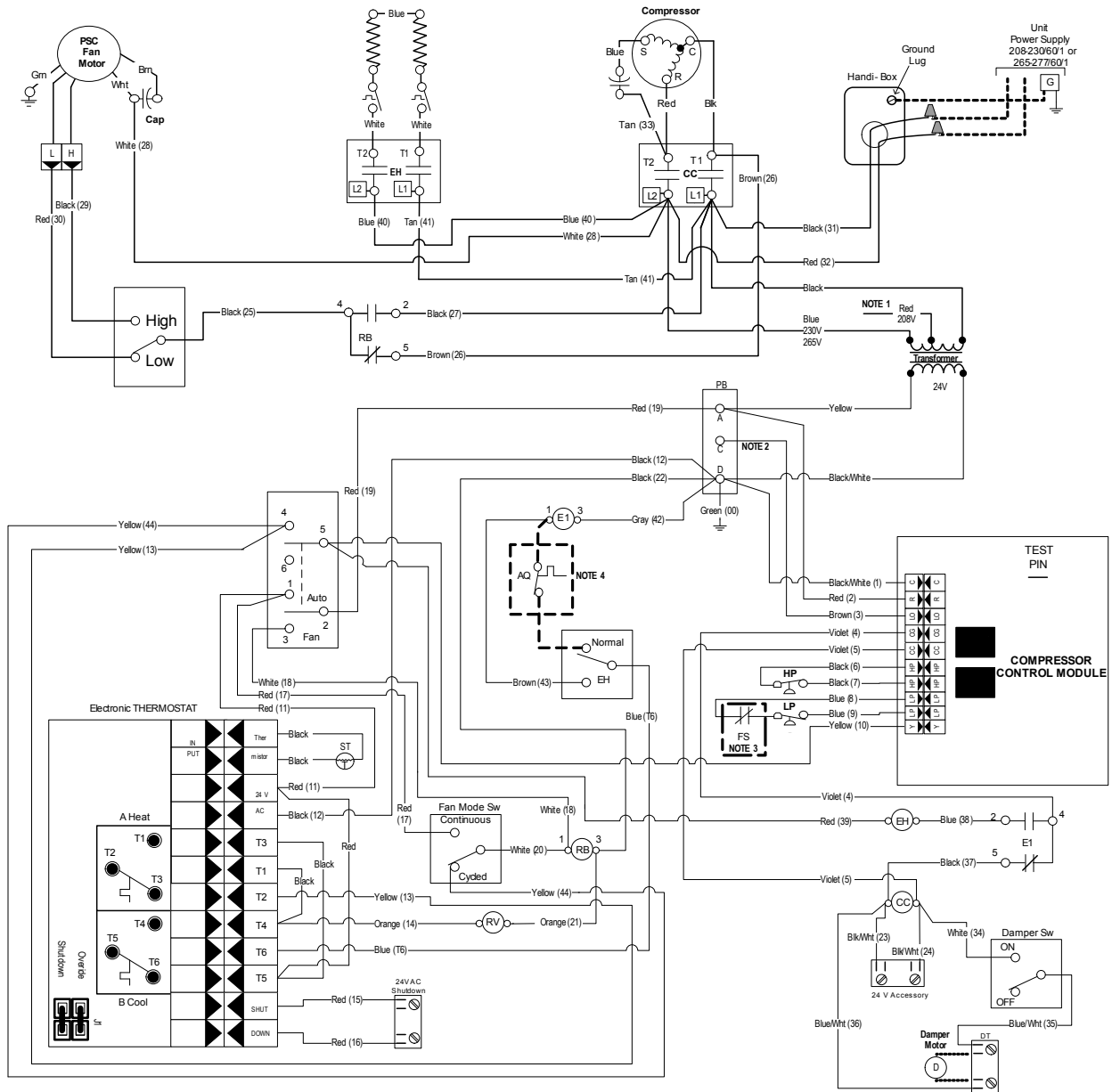

Legend			
Factory low voltage wiring	AQ - Aquastat	Field wire lug	Switch - High Pressure
Factory line voltage wiring	CC - Compressor Contactor	Earth Ground	Switch - Low Pressure
Field low voltage wiring	DT - Damper Terminal Block	Relay Contacts ND, NC	Relay coil
Field line voltage wiring	E1 - Electric Heat Relay	Polarized connector	Capacitor
Quick connect terminal	EH - Electric Heat Contactor		Thermistor
Wire nut	FS - Freeze Sensing Device		Temperature Switch
	HP - High Pressure Switch		
	LP - Low Pressure Switch		
	PB - Power Block		
	RB - Blower Relay		
	RV - Reversing Valve Coil		
	ST - Entering Air Temperature Sensor		

- Notes:**
1. Switch Red and Blue wires for 208 volt operation
 2. Terminal C of 24 V PB is used as "L" output for Brown wire3 for Lockout
 3. Optional field installed freeze sensing device.
 4. Optional field installed aquastat

6/10/08

Wiring Schematics cont.

VERSATEC CONTROL - EH & REMOTE WALL THERMOSTAT

208-230-265/60/1

Legend for Schematic [A]

Normal Control Timing Table

Blower off delay	30 seconds
Compressor on delay	10 seconds
Short cycle delay	5 minutes
Minimum compressor on time	60 seconds (except for fault condition)
High pressure fault recognition delay	Less than 1 second
Low pressure fault recognition delay	30 seconds
Freeze sensing fault recognition delay	30 seconds
Condensate overflow fault recognition delay	30 seconds
Low pressure fault bypass delay	2 minutes
Freeze sensing fault bypass delay	2 minutes
Motorized valve delay	90 seconds
Random start delay	0 - 25 seconds

Test Control Timing Table

Blower off delay	5 seconds
Compressor on delay	2 seconds
Short cycle delay	15 seconds
Minimum compressor on time	5 seconds (except for fault condition)
High pressure fault recognition delay	Less than 1 second
Low pressure fault recognition delay	30 seconds
Freeze sensing fault recognition delay	30 seconds
Condensate overflow fault recognition delay	30 seconds
Low pressure fault bypass delay	0 seconds
Freeze sensing fault bypass delay	0 seconds
Motorized valve delay	90 seconds
Random start delay	0 seconds

LED Display Mode Table

LED	Normal Display Mode
	SW1 - #4 On, SW2 Off
Drain	Drain pan overflow lockout
Water Flow	FS thermistor (loop < 15°F, well < 30°F) lockout
High Press	High pressure > 600 PSI lockout
Low Press	Low pressure < 40 PSI lockout
Air Flow	Not used
Status	Microprocessor malfunction*
DHW Limit	Not Used
HWD	SW2 status (Off = down position, On = up position)

Diagnostic Modes

LED	Current Fault Status	Inputs	Outputs
	SW1 - #4 On, SW2 On	SW1 - #4 Off, SW2 Off	SW1 - #4 Off, SW2 On
Drain	Drain pan overflow	Y	Compressor
Water Flow	FS thermistor (loop < 15°F, well < 30°F)	G	FAN
High Press	High pressure > 600 PSI	O	O
Low Press	Low pressure < 40 PSI	ES	ES
Air Flow	Not used	NS	NS
Status	Not used	LS	LS
DHW Limit	Not used	Not Used	Not Used
HWD	SW2 in the On position	Off position	On position

*Flashing Status light indicates microprocessor is functioning properly. Solid "on" indicates a microprocessor malfunction.

Versatec Logic Board Physical Layout

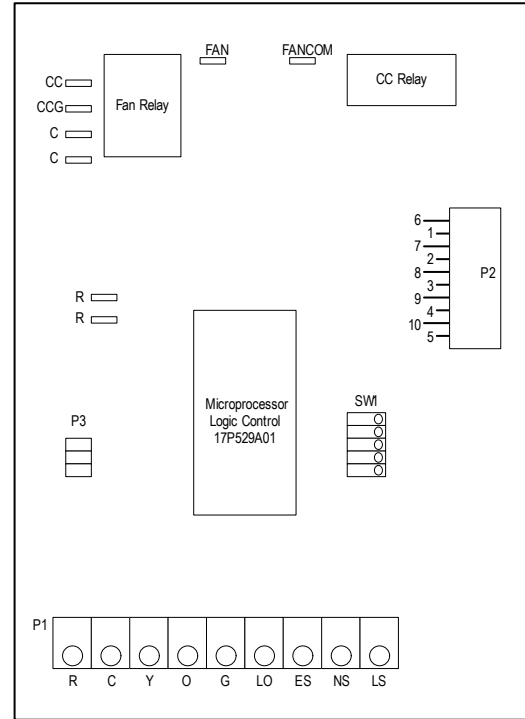

Logic Board DIP Switch Settings

Switch	OFF	ON
SW1 - 1	Test - Selected timings sped up to facilitate troubleshooting	Normal - Standard timings
SW1 - 2	Loop - Closed loop freeze sensing setting (15°F)	Well - Open loop freeze sensing setting (30°F)
SW1 - 3	Enables NS features	Normal - Standard thermostat operation
SW1 - 4	IO Display * - Enables Input/Output display on external LED board*	Normal * - Unit status display
SW1 - 5	Motorized Valve - 1.5 minute compressor on delay	Normal - Standard delay on call from compressor used
SW2	OFF * - Normal or Input display mode activated	ON * - Current fault or Output display mode activated

*Refer to LED Display Mode table for position of SW1-4 and SW2

Operational Logic Table

Mode	Inputs	Fan	Comp	RV
Htg	Y	ON	ON	OFF
Cig	Y,O	ON	ON	ON
Fan	G	ON	OFF	OFF

Wiring Schematics cont.

VERSATEC CONTROL - EH & REMOTE WALL THERMOSTAT

208-230-265/60/1

Schematic [A]

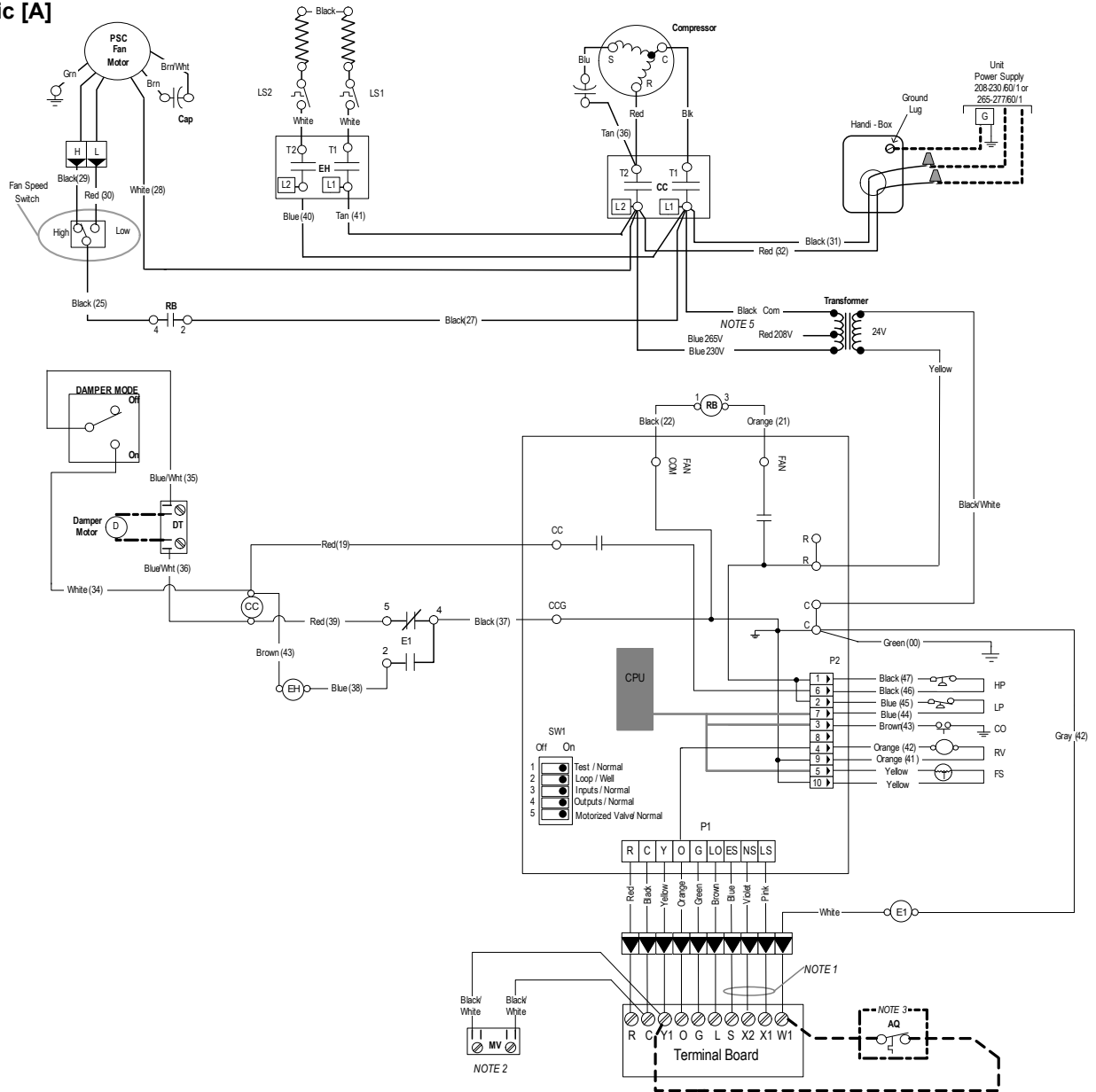

Wiring Schematics cont.

FX10 - EH

208-230-265/60/1

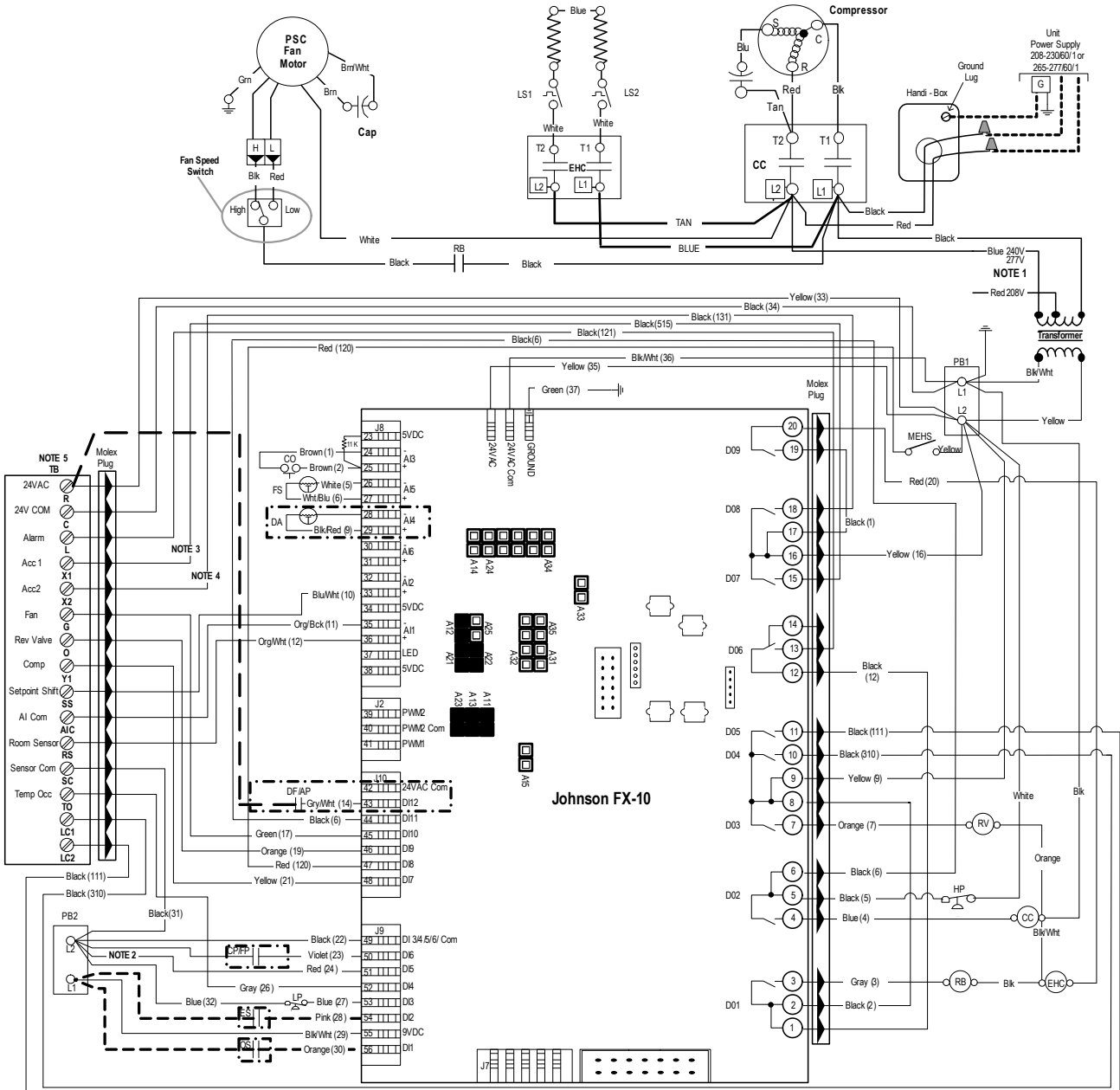

Legend

<ul style="list-style-type: none"> Factory low voltage wiring Factory line voltage wiring Field low voltage wiring Field line voltage wiring Field Zone Sensor Wiring Internal junction Quick connect terminal Wire nut Field wire lug Ground 	<ul style="list-style-type: none"> Relay Contacts N.O., N.C. Thermistor - Johnson Control Relay coil Open Jumper Closed Jumper 	<ul style="list-style-type: none"> Switch - High pressure Switch - Low pressure Polarized connector Condensate Overflow 	<ul style="list-style-type: none"> CC - Compressor Contactor CO - Condensate Overflow CRFP - Compressor Proving/Fan Proving DA - Discharge Air Temperature DFAP - Dirty Filter Air Proving EHC - Electric Heat Contactor EHR - Electric Heat Relay ES - Emergency Shutdown FS - Freeze Sensing Device HP - High Pressure Switch LP - Low Pressure Switch MEHS - Manual EHT Switch OS - Occupied Switch RB - Blower Power Relay RV - Reversing Valve Coil TB - Terminal Block <p>Notes:</p> <ol style="list-style-type: none"> 1 - Switch Blue and Red wires for 208V operation 2 - Disconnect for 15 degree freeze protection 3 - Acc 1 output is cycled with the compressor 4 - Acc 2 output is cycled with the fan 5 - R, C, Y1, O, and G inputs are for use with a wall mounted thermostat
---	--	---	---

6/10/08

Engineering Guide Specifications

General

Furnish and install Water Source Heat Pumps, as indicated on the plans. Equipment shall be completely assembled, piped and internally wired. Chassis shall be installed with factory built cabinet or other approved custom cabinet. Chassis SHALL NOT be installed without an approved cabinet enclosure. Capacities and characteristics as listed in the schedule and the specifications that follow. The reverse cycle heating/cooling units shall be floor mounted console type with horizontal air inlet and up-flow air discharge. Units shall be AHRI/ISO 13256-1 certified and listed by a nationally recognized safety-testing laboratory or agency, such as ETL Testing Laboratory. Each unit shall be computer run-tested at the factory with conditioned water and operation verified to catalog data. Each unit shall be mounted on a pallet and shipped in a corrugated box or stretch-wrapped. The units shall be designed to operate with entering liquid temperature between 20°F and 120°F [-6.7°C and 48.9°C].

Chassis & Cabinet

The cabinet shall be fabricated from heavy-gauge galvanized steel and finished with a beige textured epoxy powder coating on both sides for added protection. This corrosion protection system shall meet the stringent 1000 hour salt spray test per ASTM B117.

The cabinet shall be easily removable to allow for ease of service to the controls compartment, chassis, and piping. The top of the cabinet and grille is a horizontally flat (optional sloped) surface with a hinged control door cover. The return air filter shall be 1" (25.4 mm) fiberglass disposable type media.

The return and supply air sections are insulated with a 1/4" (6.4 mm) thick, dual density, 2 lb/ft³ (32 kg/m³) coated mat glass fiber with edges sealed or tucked under flanges to prevent the introduction of glass fibers into the discharge supply air through the aluminum grille. Standard cabinet panel insulation must meet NFPA 90A requirements, air erosion and mold growth limits of UL-181, stringent fungal resistance test per ASTM-C1071 and ASTM G21, and shall meet zero level bacteria growth per ASTM G22. Unit insulation must meet these stringent requirements or unit(s) will not be accepted.

Option: A Super Quiet Sound package shall include multi-density full coverage compressor blanket.

Option: Shipped with motorized outside air damper and damper assembly for 25% make-up air.

The drain pan shall be of stainless steel construction to inhibit corrosion and bacterial growth. Drain outlet shall be located on pan as to allow complete and unobstructed drainage of condensate. The unit as standard will be supplied with solid-state electronic condensate overflow protection with microprocessor or FX10 option. Mechanical float switches WILL NOT be accepted. Condensate tube shall be constructed of stainless steel and have an internal factory installed condensate trap.

Refrigerant Circuit

All units shall utilize the non-ozone depleting and low global warming potential refrigerant R410A. All units shall contain a sealed refrigerant circuit including a hermetic motor-compressor,

bi-directional thermostatic expansion valve, finned tube air-to-refrigerant heat exchanger, reversing valve, coaxial tube water-to-refrigerant heat exchanger, and service ports.

Compressors shall be high-efficiency single speed rotary type designed for heat pump duty and mounted on durometer grommets to provide vibration free compressor mounting. Compressor motors shall be single-phase PSC with external overload protection.

The air coil shall be sized for low-face velocity and constructed of lanced aluminum fins bonded to rifled copper tubes in a staggered pattern not less than three rows deep for enhanced performance.

Option: FormiShield™ air coil coating for maximum protection against formicary corrosion.

The coaxial water-to-refrigerant heat exchanger shall be designed for low water pressure drop and constructed of a convoluted copper (cupronickel option) inner tube and a steel outer tube. Refrigerant to air heat exchangers shall utilize enhanced corrugated lanced aluminum fins and rifled copper tube construction rated to withstand 600 PSIG (4135 kPa) refrigerant working pressure. Refrigerant to water heat exchangers shall be of copper inner water tube and steel refrigerant outer tube design, rated to withstand 600 PSIG (4135 kPa) working refrigerant pressure and 450 PSIG (3101 kPa) working water pressure. The thermostatic expansion valve shall provide proper superheat over the entire liquid temperature range with minimal "hunting." The valve shall operate bi-directionally without the use of check valves.

Option: Cupro-nickel refrigerant to water heat exchanger shall be of copper-nickel inner water tube and steel refrigerant outer tube design, rated to withstand 600 PSIG (4135 kPa) working refrigerant pressure and 450 PSIG (3101 kPa) working water pressure. Water lines shall also be of cupronickel construction.

Option: ThermaShield coated water-to-refrigerant heat exchanger, water lines and refrigerant suction lines shall be insulated to prevent condensation at low liquid temperatures below 50°F.

Blower Motor & Assembly

The blower shall be a direct drive centrifugal type with a twin dynamically balanced wheel. The housing and wheel shall be designed for quiet, low outlet velocity operation. The blower housing shall be constructed of galvanized steel and shall be removable from the unit for servicing of the blower motor. The blower motor shall be a two-speed type and shall be isolated from the housing by rubber grommets. The motor shall be permanently lubricated and have thermal overload protection.

Electrical

A control box shall be located within the unit compressor compartment and shall contain a 75VA transformer, 24 Volt activated, 2 pole compressor contactor, and solid-state controller for complete unit operation. Units shall be name-plated for use with time delay fuses or HACR circuit breakers. Unit controls shall be 24 Volt and provide heating or cooling as required by the remote thermostat/sensor.

Engineering Guide Specifications cont.

Unit mounted controls shall consist of switches for “OFF”, “FAN”, and “AUTO” or “HEAT/COOL”. An additional switch is provided for blower speed setting of “HI” or “LO”. The unit shall be equipped with a blower switch on the side of the control to provide “CONTINUOUS” or “CYCLED” blower operation. “CYCLED” blower will turn the blower on with the compressor. A unit-mounted electronic thermostat with a remote electronic thermistor located in the return air will control compressor operation in heating and cooling modes. Unit mounted thermostat shall be the standard thermostat option. All unit mounted thermostats shall be auto changeover. Manual changeover WILL NOT be accepted. Electromechanical operation WILL NOT be accepted.

Controls

Standard: A compressor control module (CCM) shall be included to disable compressor operation in the event of a trip of any of the safety switches and to send a signal to activate a fault indicator light at the thermostat. The CCM shall be capable of being reset from the thermostat or from the unit main disconnect switch. A terminal block with screw terminals shall be provided for field connection of all low-voltage wiring.

Option: Versatec microprocessor-based controller will provide operational sequencing; high and low pressure switch monitoring, freeze detection, lockout mode control, emergency shutdown mode, random start, short cycle protection, LED mode and fault indicators, fault memory, input and output diagnostics, and field selectable options, and condensate overflow sensing.

Option: FX10 microprocessor-based controller that interfaces with an electronic thermostat to monitor and control unit operation. The control shall provide operational sequencing, blower speed control, high, low and loss of charge pressure monitoring, freeze detection, condensate overflow sensing, lockout mode control, fault memory, field selectable options. The control shall communicate all mode, status, fault and lockout codes to the front end system for fast and accurate equipment diagnosis. The control shall provide fault retry three times before locking out to limit nuisance trips.

Optional FX10 microprocessor control communication protocols: N2, LonWorks, or BACnet

Option: Remote mounted thermostat is available for CCM & Versatec (standard with FX10 option). A terminal block with screw terminals will be provided for field control wiring.

Piping

Supply and return water connections shall be 1/2 in. [12.7 mm] FPT copper threaded fittings. All water piping shall be insulated to prevent condensation at low liquid temperatures.

A stainless steel tube stubbed out from the chassis is provided for condensate drain attachment. A short piece of polyvinyl hose is supplied to assist in adapting to drain.

Accessories

Hose Kits – Ball Valves (field-installed)

A flexible steel braid hose featuring Kevlar® reinforced EPDM core with ANSI 302/304 stainless steel outer braid and fire rated

materials per ASTM E 84-00 (NFPA 255, ANSI/UL 723 & UBC 8-1). Ball valve at one end; swivel connector with adapter at the other end (swivel to adapter connection via fiber or EPDM gasket). Swivel connection provides union between heat pump and piping system. The hoses feature brass fittings, stainless steel ferrules. A full port ball valve shall be provided with integral P/T (pressure/temperature) port on supply hose. Specifications: Temperature range of 35°F [2°C] to 180°F [82°C]. Max. working pressure of 400 psi [2757 kPa] for 1/2” and 3/4” hose kits; max. working pressure of 350 psi [kPa] for 1” and 1-1/4” hose kits.

Hose Kits - Automatic Balancing and Ball Valves (field-installed)

A flexible steel braid hose featuring Kevlar® reinforced EPDM core with ANSI 302/304 stainless steel outer braid and fire rated materials per ASTM E 84-00 (NFPA 255, ANSI/UL 723 & UBC 8-1). Ball valve at one end; swivel connector with adapter at the other end (swivel to adapter connection via fiber or EPDM gasket). Swivel connection provides union between heat pump and piping system. The hoses feature brass fittings, stainless steel ferrules. A full port ball valve shall be provided with integral P/T (pressure/temperature) port on supply hose and automatic balancing valve with integral P/T ports and full port ball valve on return hose. Specifications:

- Temperature range of 35°F [2°C] to 180°F [82°C].
- Max. working pressure of 400 psi [2757 kPa] for 1/2” and 3/4” hose kits; max. working pressure of 350 psi [2413 kPa] for 1” and 1-1/4” hose kits.
- Minimum burst pressure of four times working pressure.

Hose Kits – Automatic Balancing and Ball Valves with ‘Y’ strainer (field-installed)

A flexible steel braid hose featuring Kevlar® reinforced EPDM core with ANSI 302/304 stainless steel outer braid and fire rated materials per ASTM E 84-00 (NFPA 255, ANSI/UL 723 & UBC 8-1). Ball valve at one end; swivel connector with adapter at the other end (swivel to adapter connection via fiber or EPDM gasket). Swivel connection provides union between heat pump and piping system. The hoses feature brass fittings, stainless steel ferrules. A “y” strainer is provided on one end for fluid straining and integral “blowdown” valve. A full port ball valve shall be provided with integral P/T (pressure/temperature) port on supply hose and automatic balancing valve with integral P/T ports and full port ball valve on return hose.

- Specifications:
- Temperature range of 35°F [2°C] to 180°F [82°C].
 - Max. working pressure of 400 psi [2757 kPa] for 1/2” and 3/4” hose kits; max. working pressure of 350 psi [2413 kPa] for 1” and 1-1/4” hose kits.
 - Minimum burst pressure of four times working pressure.

Auxiliary Heater (field-installed 208-230V units only)

An electric resistance heater shall provide supplemental and/or emergency heating capability. A manual switch shall be mounted on the side of the control compartment with “NORMAL” or “BOILERLESS” mode. “NORMAL” will run the compressor when there is a call for heating or cooling. “BOILERLESS” mode operation will run electric heat whenever there is a call for heating and run the compressor for a cooling call.



Product: **G Series Console**
Type: Geothermal/Water Source Heat Pump
Size: 0.75-1.5 Tons

Document Type: Specification Catalog
Part Number: SC1010CG1
Release Date: 01/10